

# Quadrupole mass spectrometers in the past 30 years

History, development, future trends

Design, equipment, fields of application: Many things have changed with quadrupole mass spectrometers (QMS) over the last 30 years. They have become more compact, durable, versatile and digital. Initially used primarily in research, QMS are nowadays utilized in the semiconductor industry, freeze-drying or leak detection, for example.

#### Historical review

The first quadrupole mass spectrometers on the market included an integrated control unit in a 19 inch rack connected via cable to the analyzer and other modules such as a high-frequency generator. Figure 1 shows the QMS 420 quadrupole control unit commonly used at the end of the 1980s. This device was operated either completely via the control unit by means of a four-line LCD display and the keyboard or via PC software. A serial interface (RS-232-C) was used for communication with the computer; the softkeys below the display were applied depending on the context. Analog or digital inputs and outputs could also be used via modules. The measured values could as well be displayed via a recorder or oscilloscope channel [2].

The software available at that time consisted of different subprograms with which measurements could be performed and the QMS could be tuned. For example, to perform a measurement, a specific subprogram had to be opened. To access the stored measurement results later, one had to switch to another part of the software [3].

These first mass spectrometers were replaced in the beginning of the 1990s by compact QMS for mass ranges up to 300 amu. In contrast to the older models, the electronics of the compact versions are located directly at the vacuum feedthrough of the analyzer. This eliminates the need for additional electronics installed in the rack. The electronics of a compact QMS usually do not require much more space than the analyzer. Compared to the QMS with rack electronics, the

compact versions were moreover relatively cost-effective, but also limited in performance, especially regarding sensitivity, detection limit and measurement speed. Such devices are particularly suitable for simpler tasks such as residual gas analysis, leak detection or monitoring of specific masses over a certain period of time. To bake out the analyzer for UHV applications, however, the electronics must be removed. Figure 2 shows one of the first compact QMS.

Until the mid-2000s, most of the QMS available on the market were still equipped with a serial interface. The operation of several devices in a network and via one software – so-called "multiplexing" – was, for example, realized via ArcNet and fiber optic cables [4]. Later, devices with RS-485, USB or Ethernet interface were developed for this purpose. Ethernet allows the integration of multiple QMS into an office or production network. Wireless communication via WLAN is of course possible as well.

Also the operating software of the devices has been continuously enhanced. Operation on the control unit was almost completely replaced by software operation. All functions of the windows-based programs – setting, calibration, measurement, evaluation – were combined in one software. The display and manipulation of the data has been significantly simplified. Thanks to the programming of sequences, it has

become possible to perform measurement tasks automatically. For service tasks such as setting the mass scale or determining the sensitivity, automatic routines exist. Many manufacturers also offer the possibility to run quantitative analyses via an integrated matrix calculation as standard.

**Over the last 30 years, QMS have become more compact, durable, versatile and digital. Their fields of application have broadened.**



Figure 1: QMS 420 control unit in use in the 1980s



Figure 2: Example of one of the first compact QMS, the Prisma from Pfeiffer Vacuum

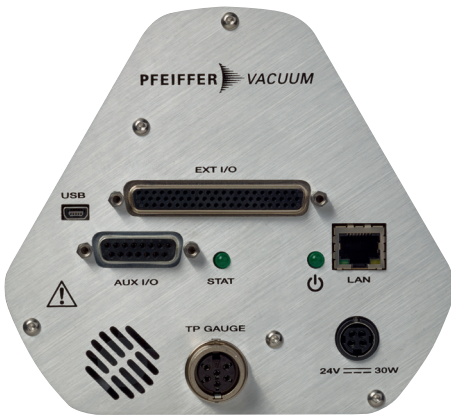

Figure 3: Interfaces on the current version of the PrismaPro compact QMS from Pfeiffer Vacuum

### Current devices

Nowadays, compact QMS dominate the market. Only in very demanding applications, QMS with rack electronics are still in use. Thanks to their high-quality detectors, they are more stable in the long term. Furthermore, the analyzers can be baked out more easily during operation and can also be used in environments with ionizing radiation or strong magnetic fields, as is required, for example, in particle accelerators or nuclear fusion experiments.

The technical data of the compact devices could be improved significantly over the years. Today, detection limits in the range of E-15 hPa are possible even with these small systems (rod diameter 6 mm, rod length 125 mm). Measuring speeds down to 1 ms/amu can also be realized, but restrict the detection limit. With a maximum of 30 W, their power consumption is quite low.

The ion source of a mass spectrometer is quite similar to the design of a hot cathode gauge. Therefore, various QMS offer the advantage of an integrated total pressure measurement. Thereby, the discharge current of the ions that hit the output aperture at the transition from the ion source to the rod system instead of flying through it is used. This protects the system from unintentional pressure rise without the use of an external gauge or additional redundancy. The modern compact devices have several interfaces. Figure 3 shows an example.

The device shown in figure 3 offers numerous analog and digital inputs and outputs thanks to the D-Sub connectors (EXT I/O and AUX I/O). The digital inputs allow, for example, previously created measurement recipes to be selected and started. The digital outputs provide a host computer with information on the status of the QMS, for example, on the state of the emission or on any error messages, and can also switch valves. Via an analog input, external signals such as temperature or gas flow can be read in. The analog outputs transmit the measured values – ion currents or concentration – to the host computer. In addition, an external total pressure gauge can be directly connected for filament protection or for calibration tasks. Communication with the PC takes place via an Ethernet interface. A mini USB plug enables communication

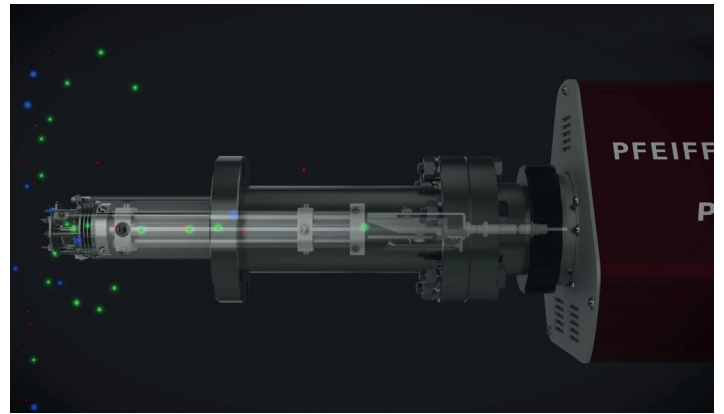

Figure 4: Inside the PrismaPro compact QMS from Pfeiffer Vacuum

with the device for service purposes [5]. In addition to communication with software, the QMS can also communicate directly with a PLC in an industrial environment. Some providers also offer LabVIEW™ \*drivers. These are primarily used in the university environment for experimental setups.

### Perspective and trends

The ever widening field of potential applications, digitalization as well as the changing demands in the markets present mass spectrometers with ever new challenges. Therefore, they must be continuously optimized and adapted to the changing conditions. Currently, two major trends for the further development of the QMS technology will be emerging within the next years.

First, the further development of the operating software: The users wish for an easy-to-use interface without having to deal with the details and theories of the QMS. Users from industry or the university environment have less and less time to familiarize themselves with the devices and their operation. This is why more detailed settings such as ion source parameters should only be available for experienced users. Some manufacturers also offer a browser-based user interface (a so-called web user interface, short: web UI, see figure 4) as an alternative to a PC program. A web server runs on the QMS, the connection is established

by entering the IP address in the browser. Most of the web UIs still only offer a reduced functionality: Often only certain measurement modes are possible or the measurement results cannot be exported [6]. Optimizing the functionality of web UIs is one of the most important starting points for future developments. Web UIs are independent of the operating system of the PCs. In addition, no software needs to be installed on the PC. Mobile devices can also be used to control the QMS.

**With the current QMS models, detection limits in the range of E-15 hPa are possible even with small systems.**





Figure 5: The PrismaPro compact QMS from Pfeiffer Vacuum



Figure 6: Web UI of a QMS on a smartphone

Second, the continuing miniaturization of the QMS, especially of the analyzers, is another trend. Relatively small rod systems (for example, 12 mm length) have already established themselves on the market – they are also used in larger quantities in high pressure applications. Thanks to its smaller dimensions, such a QMS can be used without additional pressure reduction and without its own pump system for process monitoring up to the pressure range of some E-2 hPa. However, this goes hand in hand with a reduced sensitivity, which decreases by a factor of 100 for 10 times smaller dimensions [7].

There are already several prototypes of particularly small QMS produced by the aid of MEMS technique (MEMS: microelectromechanical systems) [8]. However, these are not yet available on the market. Their major disadvantage is their sensitivity to particles. In addition, they must be produced in large quantities in order to compete with conventionally manufactured QMS. Against this background, it is questionable whether MEMS-based QMS will prevail on the market.

#### Broad portfolio for a wide variety of applications

Pfeiffer Vacuum's product portfolio comprises a broad spectrum of analyzers for the determination of gases in various vacuum processes, ranging from mass spectrometers to complex analytical systems. The basis for most solutions is our mass spectrometer PrismaPro. The Prisma is a universal mass spectrometer with high sensitivity, a compact and modular design as well as user-friendly software. It is ideal for the use in leak detection, semiconductor industry, glass

coating, metallurgy and of course in countless fields of research and development. Moreover, Pfeiffer Vacuum also offers systems for the analysis in high and ultra-high vacuum as well as high-end mass spectrometers.

#### Bibliography

- [1] W. Paul and H. Steinwedel, Zeitschrift für Naturforschung, 8a, S. 448 ff., 1953
- [2] BALZERS Aktiengesellschaft, Betriebsanweisung Quadrupol Massenspektrometer Steuergerät QMS 420, BK 800 120 BD, 2. Ausgabe: 7.1986
- [3] Pfeiffer Vacuum GmbH, Betriebsanleitung Quadstar 32-bit, vpb68d1, März 2002
- [4] Pfeiffer Vacuum GmbH, Massenspektrometer Katalog, PK 0085 PD, Juni 2005
- [5] Pfeiffer Vacuum GmbH, Broschüre PrismaPro, PK 0115 PDE, November 2017
- [6] Pfeiffer Vacuum GmbH, Betriebsanleitung Web UI, BG 6002 BDE, November 2017
- [7] K. Jousten (Hrsg.), Wutz Handbuch Vakuumtechnik, 11. Auflage, S. 679 ff., 2012
- [8] S. Wright et al., Journal of Microelectromechanical Systems, Vol. 19, No. 2, S. 325 ff., April 2010

\*LabVIEW is a trademark of the National Instruments Corporation

All data subject to change without prior notice. PI0469PEN (August 2018/0)