



Vacuum Components Vacuum Chambers

Standard and custom-made vacuum components, chambers and solutions



Industry



Research & Development

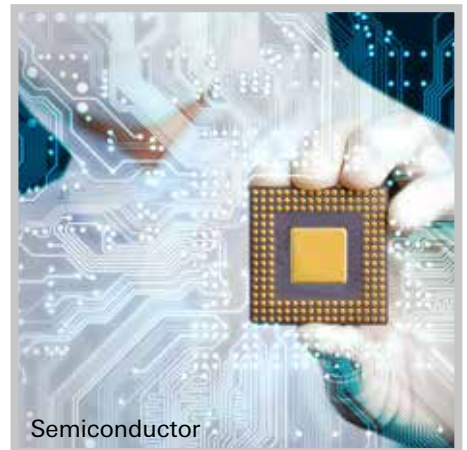

Semiconductor

Components and Chambers

Standard and custom-made

A vacuum system consists of several individual parts, which have to be joined together to form a unit. Detachable, vacuum-sealed flange connections allow components to be connected directly or with vacuum components such as pipes or hoses. Pfeiffer Vacuum offers components with various flange systems that meet the connection standards for many applications and flange sizes.

The selection of proper materials and the use of high-quality production and cleaning technologies meet the high standards of vacuum technology and lead to a high degree of tightness and low outgassing rates (desorption). The broad range of standard components in stock guarantee fast delivery availability. Pfeiffer Vacuum also offers more than standard solutions. Components can be modified to meet your requirements or a customized solution can be produced to perfectly fit your needs.

We are a one-stop supplier for all stages of the process: assistance in finding the right solution for your application, design, manufacture, quality assurance, installation and on-site service.

Table of contents

Vacuum Components

- ISO-KF
- ISO-K / ISO-F
- CF

Feedthroughs

- Rotary Feedthroughs
- Rotary-/Linear Feedthroughs
- Linear Feedthroughs

Manipulators

- XY-Axis Precision Manipulator
- Z-Axis Precision Manipulator
- Port Aligner for Angular and Linear Adjustment

Viewports

Vacuum Chambers and Solutions



One of Europe's largest
supplier of vacuum
components



Short delivery time –
24 hours in Germany,
48–72 hours in Europe



Your added value



Standard catalogue
goods and customer-
specific products



About 750.000
items generally
in stock



High availability
(>98 %)



Vacuum component warehouse at Pfeiffer Vacuum Components & Solutions in Göttingen with more than 750,000 parts in stock

ISO-KF

“Kleinflansch” for Backing
and High Vacuum (HV)



Wide range of component
types, materials and sizes –
optimally suited for your
vacuum system



Your added value



Helium tested for
highest quality
standards



Extensive
standardized system
components for
perfect compatibility

Designed for HV applications

- Suitable for pressures up to 10^{-8} hPa.
- Can be used for overpressures up to 1,500 hPa
- Two symmetrical flanges and one elastomer O-ring seal, which is positioned by a centering ring
- Pressing force created by a clamping ring
- Efficient assembly and disassembly without any tools
- According to DIN 28403 and ISO 2861
- Nominal diameter DN 10 up to DN 50

Extended pressure range to less than 10^{-9} hPa
by using metal seals

- Significantly higher pressing force required,
created by special clamps

Alternative mounting on a base plate

- Pressing force by claw clamps or bulkhead clamps

Material:

- 1.4301/304
- 1.4404/316
- Aluminum
- Further material on request

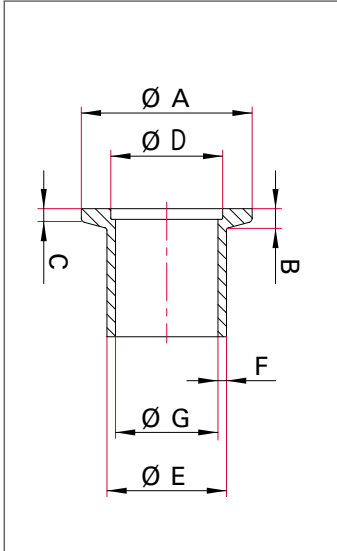

Primary dimensions of ISO-KF flanges

Nominal diameter	DN 10 ISO-KF	DN 16 ISO-KF	DN 25 ISO-KF	DN 40 ISO-KF	DN 50 ISO-KF
A – External diameter [mm]	30	30	40	55	75
A – External diameter [inch]	1.18	1.18	1.57	2.17	2.95
B – Flange height [mm]	5	5	5	5	5
C – [mm]	3	3	3	3	3
D – Centering ring set [mm]	12.2	17.2	26.2	41.2	52.4
E · F – Typical pipe dimension ¹⁾ [mm]	14 · 2	20 · 2	28 · 2	44.5 · 2	57 · 3.2
G – Typical internal diameter ²⁾ [mm]	10	16	24	40.5	51

¹⁾ Additional pipe dimensions can be found particularly in the products “bored flange” and “half nipple”.

²⁾ The minimum inner diameter is determined by the combination of flange, pipe and centering ring.

In addition, welding seams and manufacturing tolerances of the pipes can locally reduce the free diameter.

ISO-KF

“Kleinflansch” for Backing
and High Vacuum (HV)

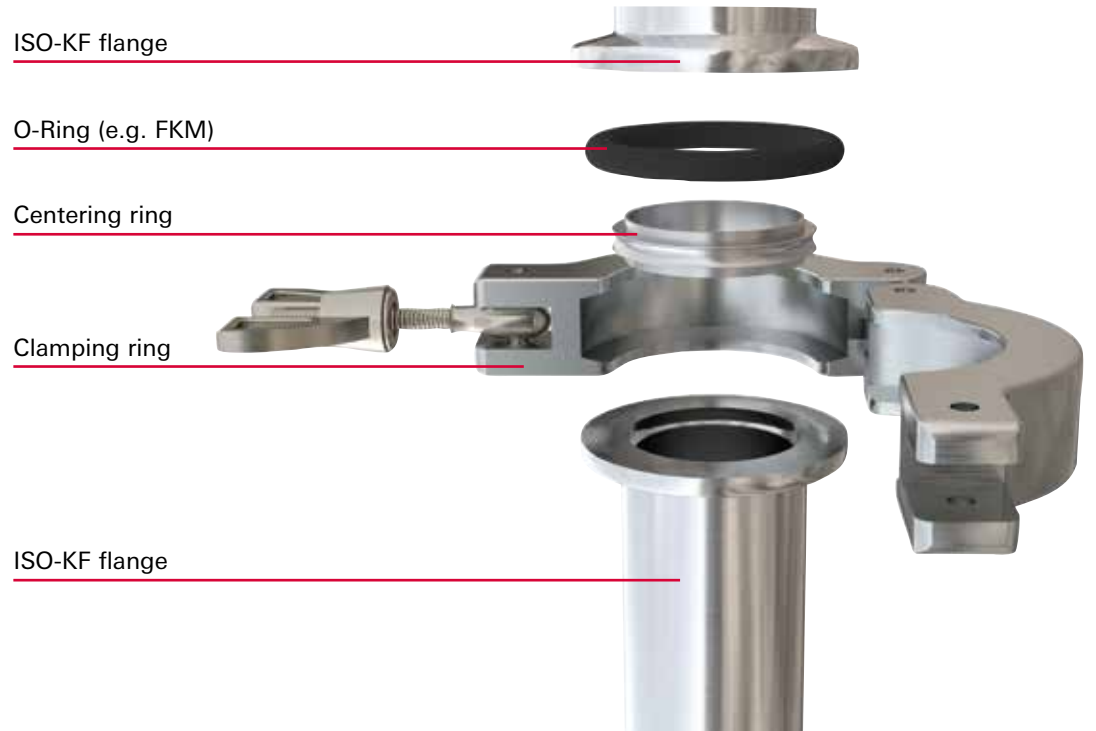

Chamber with different flange geometries

Operating principle ISO-KF with clamping ring



ISO-KF on base plate with bulkhead clamp and blind holes



ISO-KF on base plate with blind holes and single claw clamp



ISO-K / ISO-F

Clamping flange for Backing- and High Vacuum (HV)



Wide range of component
types, materials and sizes –
optimally suited for your
vacuum system



Your added value



Helium tested for
highest quality
standards



Extensive
standardized system
components for
perfect compatibility

Designed for HV applications

- Suitable for pressures up to 10^{-8} hPa.
- Can be used for overpressures up to 1,500 hPa
- Two symmetrical flanges and one elastomer O-ring seal, which is positioned by a centering ring
- Pressing force created claw clamps (ISO-K) respectively screws (ISO-F)
- Combination of ISO-K with ISO-F flanges possible due to rotatable bolt rings
- According to DIN 28404 and ISO 1609
- Common used sizes:
DN 63 ISO-K, DN 100 ISO-K, DN 160 ISO-K...DN 630 ISO-K
up to DN1000 ISO-F

Extended pressure range to less than 10^{-9} hPa
by using metal seals

- Significantly higher pressing force required. ISO-F flanges with screws recommended. For ISO-K flanges increase the number of claw clamps.

Material:

- 1.4301/304
- 1.4404/316
- Aluminum
- Further material on request

Dimensions

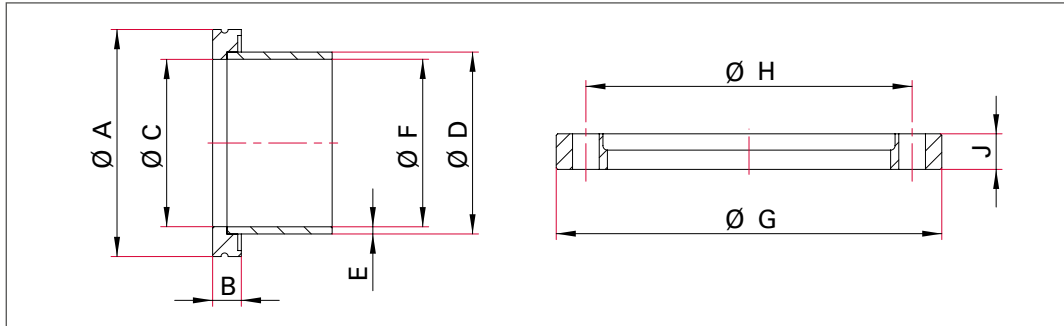

Primary dimensions for ISO-K and ISO-F flanges

Nominal diameter	DN 63 ISO-K	DN 80 ISO-K	DN 100 ISO-K	DN 160 ISO-K	DN 200 ISO-K	DN 250 ISO-K	DN 320 ISO-K	DN 400 ISO-K	DN 500 ISO-K	DN 630 ISO-K
A - External diameter [mm]	95	110	130	180	240	290	370	450	550	690
A - External diameter [inch]	3.74	4.33	5.12	7.09	9.45	11.42	14.57	17.72	21.65	27.17
B - Flange height [mm]	12	12	12	12	12	12	17	17	17	22
C - Centering ring set [mm]	70	83	102	153	213	261	318	400	501	651
D · E - Typical pipe dimension ¹⁾ [mm]	76.1 · 3	88.9 · 3	108 · 3	159 · 3	219 · 3	273 · 3	324 · 3	406 · 3	508 · 4	660 · 5
F - Typical internal diameter ²⁾ [mm]	70	83	102	153	213	261	318	400	500	650
G - External diameter [mm] ISO-F flange and FLU ³⁾	130	145	165	225	285	335	425	510	610	750
H - Bolt holes [mm] ISO-F flange and FLU ³⁾	110	125	145	200	260	310	395	480	580	720
J - Height [mm] ISO-F flange and FLU	12	12	12	16	16	16	20	20	20	24
Number of bore holes · diameter [mm] ISO-F flange and FLU ³⁾	4 · 9	8 · 9	8 · 9	8 · 11	12 · 11	12 · 11	12 · 13.5	16 · 13.5	16 · 13.5	20 · 13.5
Recommended number of bracket screws for elastomer seals ⁴⁾	4	4	4	4	6	6	8	8	12	12
Minimal number of bracket screws for aluminum edged seal ⁴⁾	4	6	6	8	10	12	-	-	-	-
Number of claws / screws	4 · M8	8 · M8	8 · M8	8 · M10	12 · M10	12 · M10	12 · M12	16 · M12	16 · M12	20 · M12

¹⁾ Additional pipe dimensions can be found particularly in the products “bored flange” and “half nipple”.

²⁾ The minimum inner diameter is determined by the combination of flange, pipe and centering ring. In addition, welding seams and manufacturing tolerances of the pipes can locally reduce the free diameter.

³⁾ FLU = Rotatable bolt ring

⁴⁾ Note the installation instructions for the component!

ISO-K / ISO-F

Clamping flange for Backing-
and High Vacuum (HV)

Functional principles ISO-K / ISO-F

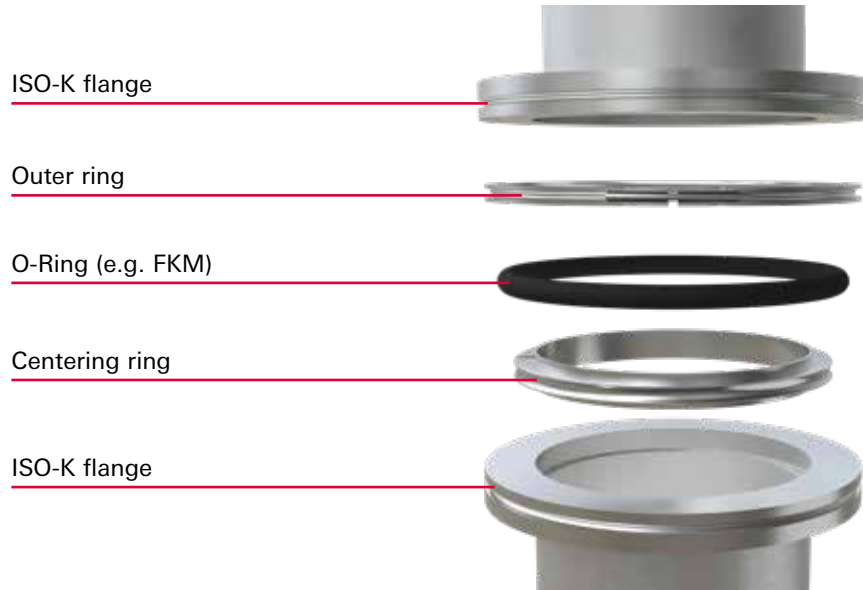

ISO-K connection with double claw clamp



ISO-F centering ring same like ISO-K



ISO-K on base plate with blind holes and single claw clamp



Functional principles ISO-K / ISO-F

Adaption ISO-K -> ISO-F



ISO-F with blank flange



ISO-F on base plate with blind holes



CF

Suitable for ultra-high vacuum applications (UHV)



Wide range of component types, materials and sizes – optimally suited for your vacuum system



Your added value



Helium tested for highest quality standards

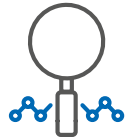

Low desorption rate guaranties uniquely clean vacuum

Designed for UHV applications

- From ambient pressure up to less than 10^{-12} hPa
- Bakable up to 450°C
- Two symmetrical flanges with knife-edge and flat copper gasket which is positioned in a sealing recess
- Sufficient number of screws which provide the necessary high pressing force
- Knife-edges press into the copper seal and form a hermetically sealed connection (gasket cannot be reused)
- According to ISO 3669 in nominal diameters DN 10 to DN 400
- For nominal sizes larger than DN 250 different flange dimensions are still common

Material:

- Stainless steel with low carbon content 1.4307 - sufficient for many applications
- For higher demands, e.g. regarding strength or low magnetizability premium steel 1.4429 ESR is recommended



Dimensions for CF flange

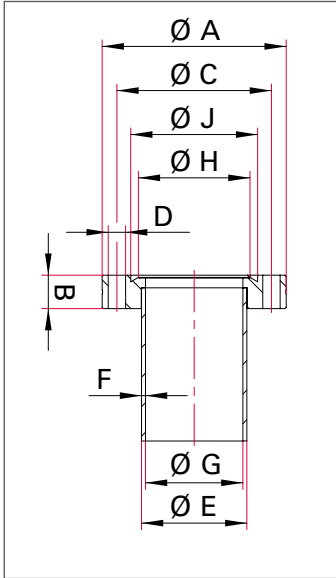

Primary dimensions of CF flanges

Nominal diameter	DN 16 CF	DN 25 CF	DN 40 CF	DN 50 CF	DN 63 CF	DN 75 CF	DN 100 CF
A – External diameter [mm]	34.0	54.0	69.9	85.7	113.5	117.4	152.0
A – External diameter [inch]	1-1/3	2-1/8	2-3/4	3-3/8	4-1/2	4-5/8	6
B – Flange height [mm]	7.75	12.0	12.7	17.3	17.5	17.5	19.8
C – Bolt hole diameter for screws [mm]	27.0	41.3	58.7	72.4	92.2	102.3	130.3
D – Number · Diameter Screw bore holes [mm]	6 · 4.4	4 · 6.6	6 · 6.6	8 · 8.4	8 · 8.4	10 · 8.4	16 · 8.4
E · F – Typical outside pipe diameter ¹⁾ [mm]	18 · 1	28 · 2	40 · 1.5	50.8 · 1.65	70 · 2	76.1 · 2	108 · 2
G – Typical internal diameter ²⁾ [mm]	16	24	37	47.5	66	72.1	104
H – Diameter cutting edge [mm]	18.3	27.7	41.9	55.9	77	86.2	115.3
J – Diameter groove for flange seal [mm]	21.4	33.0	48.25	61.8	82.5	91.6	120.6

Nominal diameter	DN 130 CF	DN 160 CF	DN 200 CF	DN 250 CF	DN 300 CF	DN 350 CF
A – External diameter [mm]	171.4	202.4	253.2	304.8	355.6	419.1
A – External diameter [inch]	6-3/4	8	10	12	14	16.5
B – Flange height [mm]	21.4	22.2	24.5	26.0	28.5	28.5
C – Bolt hole diameter screws [mm]	151.6	181.0	231.8	284.0	325.4	388.9
D – Number · Cross section Screw bore holes [mm]	18 · 8.4	20 · 8.4	24 · 8.4	32 · 8.4	30 · 10.5	36 · 10.5
E · F – Typical outside pipe diameter ¹⁾ [mm]	127 · 1.65	159 · 2	205 · 2.5	256 · 3	306 · 3	356 · 3
G – Typical internal diameter ²⁾ [mm]	123.7	154.5	200	250	300	350
H – Diameter cutting edge [mm]	136.3	166.1	216.9	267	308.9	370.7
J – Diameter groove for flange seal [mm]	141.8	171.4	222.2	273.1	313.5	376.8

¹⁾ Additional pipe dimensions can be found particularly in the products “bored flange” and “half nipple”.

²⁾ The minimum internal diameter is determined by the combination of flange, pipe and seal. In addition, welding seams and manufacturing tolerances of the pipes can locally reduce the free diameter.

Feedthroughs

Transfer of electrical power, signals, fluids or mechanical movements into a vacuum

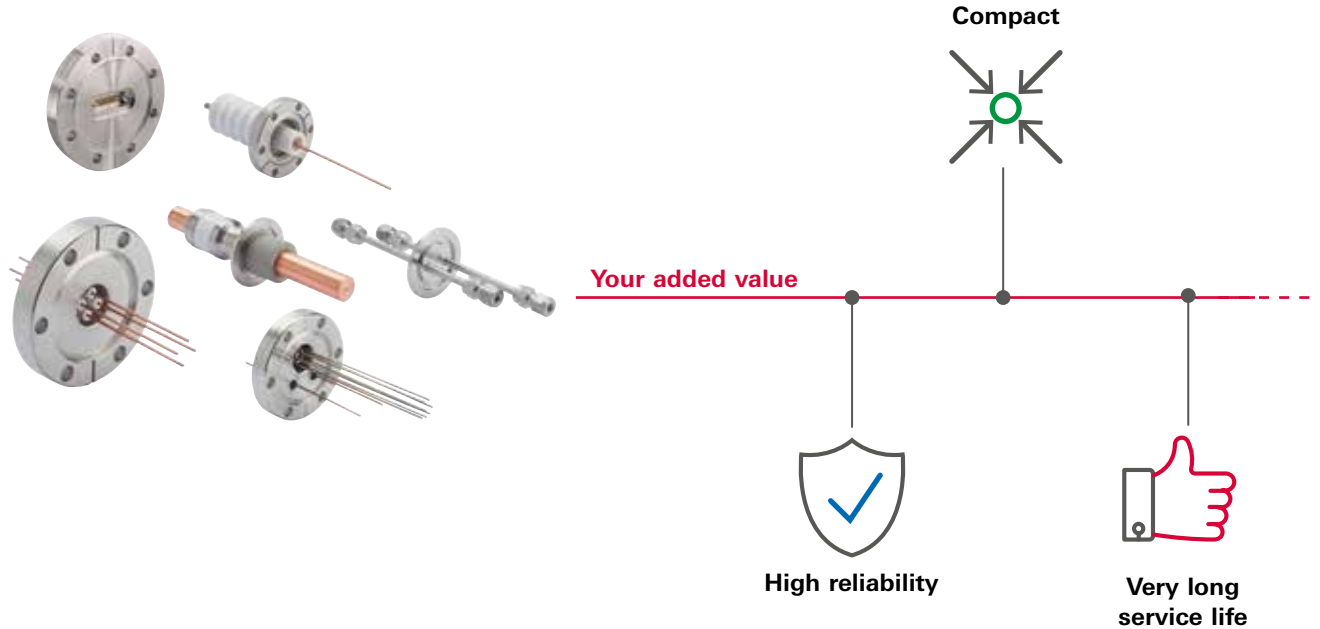

Pfeiffer Vacuum offers you a diverse selection of vacuum feedthroughs for electrical power, voltages, thermocouples and fluids in all flange lines for high vacuum and ultra-high vacuum applications. Moreover, you will find mechanical vacuum feedthroughs for rotary, linear and rotary/linear movements, elastomer sealed for the high vacuum range, magnetically coupled or bellows-sealed for ultra-high vacuum applications.



Rotary Feedthroughs

Elastomer-sealed Rotary Feedthroughs
DN 16 - 40 ISO-KF und DN 63 ISO-K

- With FKM shaft seal and ball bearing, greased to be suitable for vacuum
- The rotation speed can be increased by up to a factor of two if reduced service life is acceptable
- Through shaft for directly transmitting high torques



Magnetically coupled Rotary Feedthroughs

- Magnetic coupling with samarium-cobalt magnets
- Stainless steel ball bearing with dry lubrication suitable for UHV
- Hermetically sealed, suitable for UHV
- Fixing brake



Bellows-sealed Rotary Feedthroughs

- Hermetically sealed, suitable for UHV
- Bellows-sealed
- Stainless steel ball bearing with dry lubrication, suitable for UHV



Bellows-sealed Precision Linear Feedthroughs

- Hermetically sealed, suitable for UHV
- Bellows-sealed
- Manual, Fine
- Bakeout temperature: max 300°C



Elastomer-sealed Rotary / Linear Feedthroughs

Elastomer-sealed Rotary/Linear Feedthrough
Long Version MDD, Short Version DS

- Direct power transmission using elastomer-sealed shaft
- Freely rotatable and slidable
- Adjustable stroke limiting stops
- Bakeout temperature: < 110°C



Magnetically coupled Rotary/Linear Feedthrough

- Stainless steel ball bearing for linear and rotational movement with dry lubrication suitable for UHV
- Magnetic coupling with samarium-cobalt magnets
- Hermetically sealed, suitable for UHV

Manipulators

To tilt probes or components under vacuum

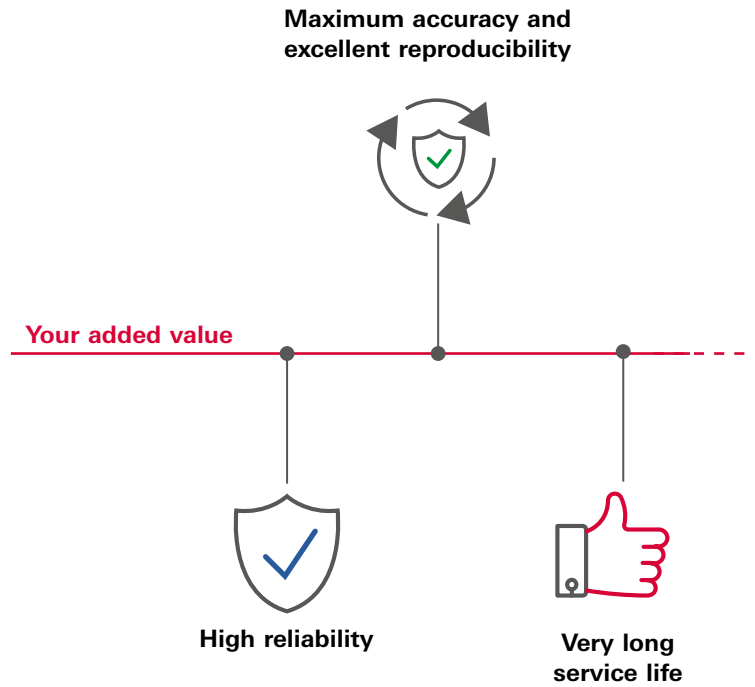

Manipulator flanges are subjected to sizable forces due to atmospheric pressure, particularly where large nominal diameters are involved. To ensure that flanges remain in a stable position even under vacuum, we place great importance on the inherent rigidity when designing our manipulators and optimize them by using the Finite Elements Method (FEM) in our calculations. Together with the installation of high quality mechanical components this means that movements are extremely precise, smooth and free of play with excellent reproducibility. The low wear also means higher reliability and a very long service life.



XY-Axis Precision Manipulator

- Precision cross roller guides
- Zero-backlash and no slip-stick effect
- Guidance and drive wear-free and maintenance-free
- Extremely stable design concept minimizes position offset due to pressure changes



Z-Axis Precision Manipulator

- Recirculating ball bearing guides and recirculating ball screw drive
- Zero backlash and no slip-stick effect
- Guide and drive are wear-free and maintenance-free
- Extremely stable design concept minimizes position offset due to pressure changes



Port Aligner for Angular and Linear Adjustment

- Ball joints for easy angular adjustment
- Adjustment angle: 3°
- Maximum angle and stroke simultaneously usable
- Flanges with through holes

Viewports

To visually observe processes or specific transfer of electromagnetic waves

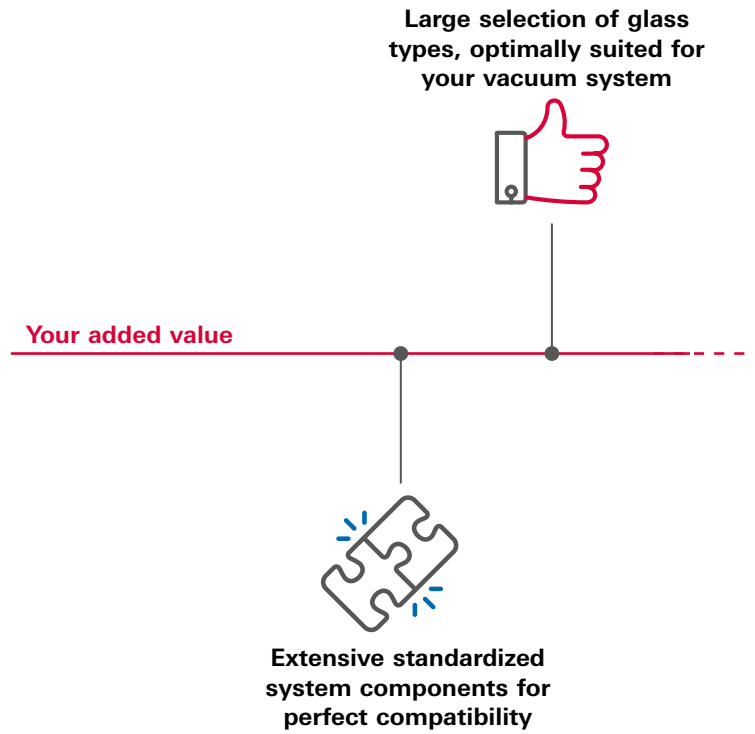

Viewports are mainly used to visually observe processes. They can, however, also be used for the specific transfer of electromagnetic waves. For this, the transmission and the optical quality of the glasses should be considered.

We provide different glass material combined with various types of vacuum flange to suit your specific application.

Viewports

- ISO-K, ISO-F, CF Viewports
- CF Shutter
- ISO-KF, ISO-K, CF Glass Retainers
- Glasses for Retainers

Standard and custom-made vacuum chambers and solutions

At the heart of a vacuum system is the vacuum chamber that offered as either standard or customized for your specific application. Pfeiffer Vacuum's vacuum chambers meet the highest quality and engineering standards providing vacuum solutions precisely designed to meet our customers' needs. They are used for medium vacuum to ultra-high vacuum applications and can also be designed, produced and tested as pressure chambers for overpressure of more than 500 hPa in accordance with the Pressure Equipment Directive (97/23/EC).

The range of vacuum chambers extends from small recipients for lab applications to large-sized space simulation and coating chambers. Pfeiffer Vacuum offers full service from a single source: Application consultation, design, production, quality assurance, assembly and on-site service. From the design to project management and finishing, we will provide you a perfect vacuum solution: high quality vacuum chambers in single item and serial production.

Your advantages

- Vacuum solutions designed precisely for your application
- Safe and reliable
- Full service from a single source
- Versatile applications

Nominal size							Pressure range			Temperature range	
DN 250	DN 300	DN 320	DN 400	DN 500	DN 600	DN 750	1 · 10 ⁻⁷ hPa up to ambient pressure	1 · 10 ⁻⁷ hPa to 500 hPa overpressure	1 · 10 ⁻⁵ hPa up to ambient pressure	-15 to 150°C	0 to 40°C

Standard vacuum chambers

High vacuum chambers, cubical with stainless steel door		■			■		■	■		■	
High vacuum chambers, cubical with acrylic glass door		■			■		■		■		■
High vacuum chambers, horizontal			■	■	■	■	■			■	
High vacuum chambers, vertical			■	■	■	■	■			■	
Medium vacuum chambers, vertical with acrylic glass cover	■		■	■					■		■
Modular vacuum chambers			■	■	■			■		■	

Vacuum Chambers

Standard and custom-made vacuum chambers and solutions

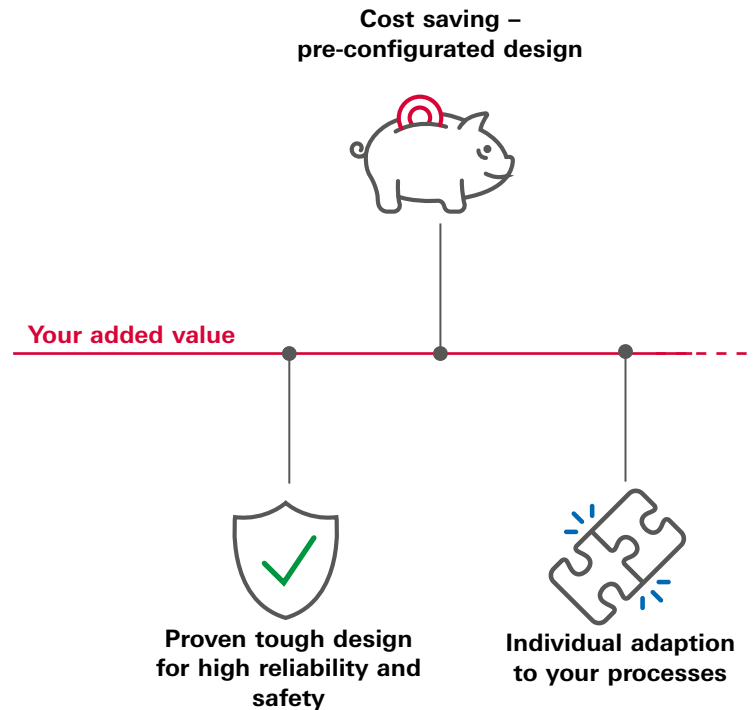
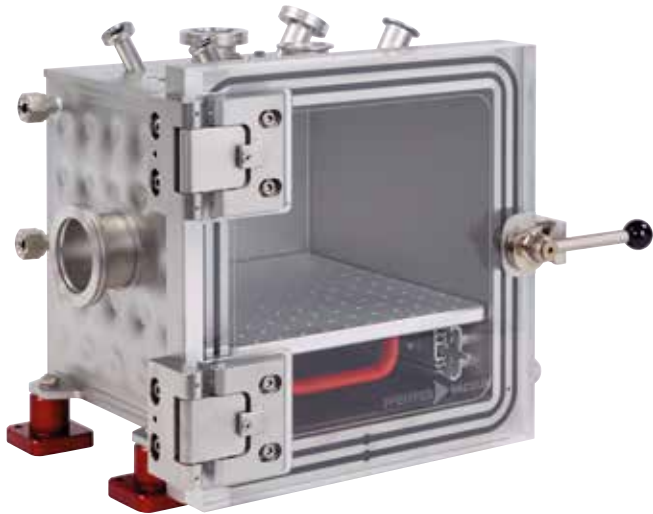

Standard Vacuum Chambers

Standardized chambers for your vacuum applications

Standard vacuum chambers are standardized shapes where you can select the port types and locations. They can be configured to the vacuum solution you need.

Customer benefits

- Pre-configured shapes
- Customized ports
- Proven robust design

Typical applications

- Research & development
- Semiconductor
- Coating
- Analytics
- Industry

Series high vacuum chambers are designed for a pressure range from ambient pressure up to $1 \cdot 10^{-7}$ hPa. Standardized base bodies are available in four versions: Cubical, cylindrical-horizontal, cylindrical vertical and modular chamber system. Nominal sizes are available from 250 mm to 750 mm.



High vacuum chamber



Medium vacuum chamber



Modular chamber components

Vacuum Chambers

Standard and custom-made vacuum chambers and solutions

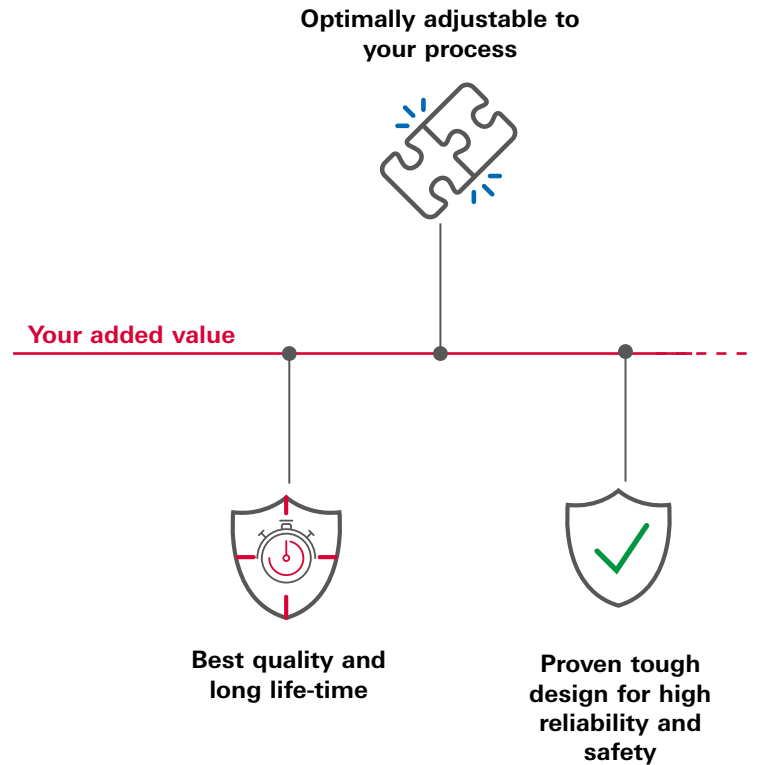

Custom vacuum chambers

Individually designed chambers for your vacuum applications

With many years of experience we have the know-how of virtually all requirements and can provide professional guidance for system specifications, design and engineering. Our physicists, designers, project managers and production specialists have extensive experience in a wide range of uses in all market segments. The tasks are based on your requirements: our starting point on the path to a finished product can range from a rough sketch to a complete set of blueprints. Our customers include a great number of renowned large research facilities and universities, who we supply with UHV vacuum chambers, cryostats and accelerator components as well as reputable customers from industry, whose development and production areas we equip with vacuum chambers.

Customer benefits

- Individual design
- Proven, robust design
- Optimal process adaption
- Extensive systems guidance typical applications
- For all areas of vacuum technology

All vacuum chambers

- Can be adapted to meet technical requirements
- Can be equipped with the necessary accessories
- Are tested for leaks

Technical design Vacuum chambers are produced using high-quality materials. Special cleaning procedures guarantee contamination-free, vacuum-stable surfaces, to meet the highest of standards and are ready for immediate installation. All production phases are documented and quality tested in each production phase. You will receive a quality report containing the leak test log and other test results.

Standards

We use 1.4301 (304) stainless steel for pipes, chamber walls and ISO flanges and 1.4307 (304 L) for CF flanges. Premium stainless steel 1.4429 ESU (316 LN ESR) is available to provide minimum outgassing rate and high strength even after vacuum annealing above 950°C. Our standard interior and exterior treatment is glass bead blasted. Surfaces can be sanded, sanded and electro-polished, chemically pickled and passivated, as well as vacuum annealed.

Options

Your vacuum chamber can be expanded in numerous ways. We offer an extensive selection of accessories, fittings and attachments. We can also supply the following services upon request:

- Chamber materials: additional stainless steels and aluminum alloys
- Material certification
- Water cooling: as C-channel, pillow plate cooling or double walled.
- Chamber frames
- Chamber heating
- Cleaning and demagnetization annealing under vacuum
- Design and production of a pressure chamber
- FEM (Finite Element Method) calculations
- Assembly under cleanroom conditions

Product testing

In addition to the standard, sniffing helium leak test. Other tests can be carried out:

- Helium leak testing (local and integral)
- Baking-out and final vacuum residual gas analysis
- Pressure testing
- 3D check
- Permeability testing
- Electrical insulation testing
- Dye penetrant inspection
- X-ray inspection of welding seam
- X-ray Fluorescence Analyzer (XRF)

On request, we will also be happy to put together a system for you that includes all ports, matching pumps, components and valves.

Your Success. Our Passion.

We give our best for you every day –
worldwide!

Are you looking for your
optimized vacuum solution?
Please contact us:

**Pfeiffer Vacuum
Components & Solutions GmbH**
Germany
T +49 551 999 63-0



Follow us on social media
#pfeiffervacuum



www.pfeiffer-vacuum.com

PFEIFFER  **VACUUM**