



HiScroll®

The extremely quiet, compact, oil-free pump.
Reducing your carbon footprint.

The extremely quiet, compact, oil-free pump. Reducing your carbon footprint.

HiScroll – the oil-free vacuum pumps

The HiScroll series consists of three dry and hermetically sealed scroll pumps with a nominal pumping speed of 6–20 m³/h. The pumps are especially characterized by their high performance when evacuating against atmosphere due to their unique features. Their powerful IPM¹⁾ synchronous motor achieves an efficiency that is up to 15% higher than that of conventional drives. This enables maximum performance at low temperatures, which results in more efficient cooling of compact systems and equipment.

Intelligent control

The adaptive cooling control of the HiScroll ensures optimal cooling in different operating conditions and also reduces noise emissions when the full performance of the pump system is not required. An integrated pressure sensor (optional) enables fully automatic pressure regulation together with intelligent speed control. This helps to minimize wear and noise emissions and ensures longer maintenance intervals.

HiScroll pumps can be easily connected to other Pfeiffer Vacuum products (such as turbopumps or display and control units) as well as to a higher-level external control system, via RS-485 or ProfiNet. The integrated intelligent control also enables the setting and holding of specific pressures via the automatic regulation of the speed of the pump.

¹⁾ Interior Permanent Magnet

Customer benefits

- No hydrocarbons: Absolutely dry and oil-free vacuum pump
- Low noise level, little vibration and compact design for use in the laboratory
- Safe operation due to integrated safety valve and hermetically sealed pump system
- Industry 4.0: Operation with other intelligent products by Pfeiffer Vacuum, such as turbopumps via RS-485
- Low COO thanks to highest quality, short service times and long maintenance intervals
- Economical & comfortable: Fully automatic pressure regulation between 0.1 - 30 hPa (optional)



Applications

- Mass spectrometry
- Accelerators
- Laboratories
- Leak detection
- Semiconductor technology
- Coating
- Gas recovery
- Vacuum drying

The extremely quiet, compact, oil-free pump. Reducing your carbon footprint.

Lowest noise emission on the market

The HiScroll pumps are extremely quiet with <47 dB [A] (in stand-by mode <42 dB [A]). The pumps are also very compact with low-vibration operation, which are ideally suitable for applications in mass spectrometers, research & development institutes or leak detection systems.

High safety at lower costs

The two-stage gas ballast ensures high water vapor tolerance. It also enables a more individual adjustment to your process. The built-in check valve and the self-regulating option ensure vacuum integrity.

The proven quality of Pfeiffer Vacuum components ensures the long lifetime of the pumps. The maintenance of the pumps is simple and enables short service times while the efficient motor helps to reduce electricity costs.

Customer benefits

- Quiet, self-regulating air cooling system
- Performance as required: Stable pumping speed and short cycle times
- Comfort and efficiency: Stand-by mode and automatic pressure control due to RPM regulation (optional)
- Sustainable: 15% higher motor efficiency, resulting in less heat generation and lower cooling requirements
- Easy logistics: HiScroll pumps can be operated at any voltage
- Minimal maintenance costs due to easy service concept



Coating



Vacuum drying



Accelerators



To reduce your carbon footprint.



Laboratories



Mass spectrometry



Semiconductor technology

The extremely quiet, compact, oil-free pump.
Reducing your carbon footprint.

Performance as required

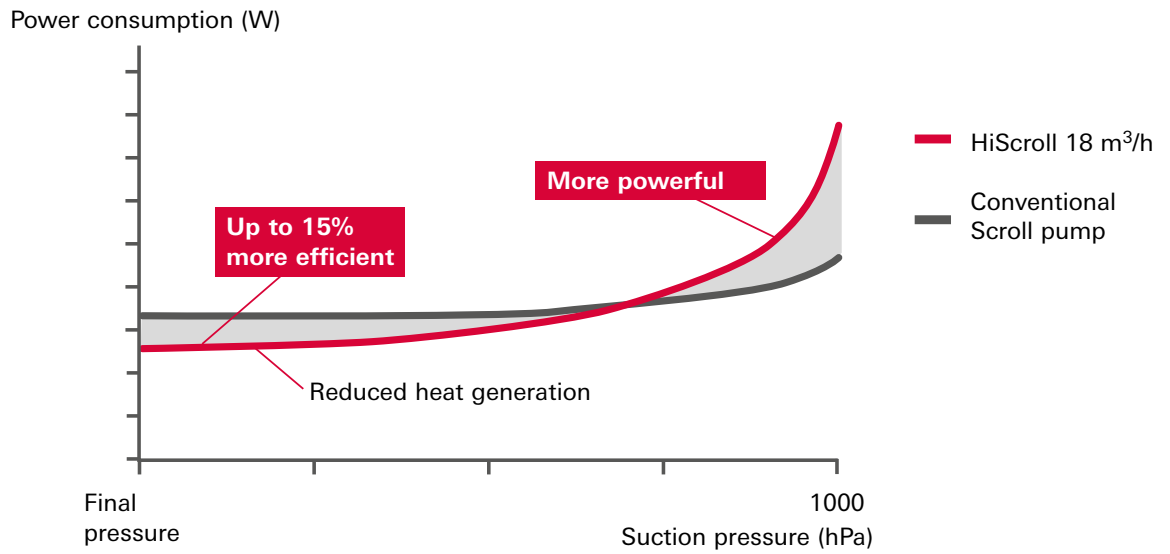

Constant pumping speed

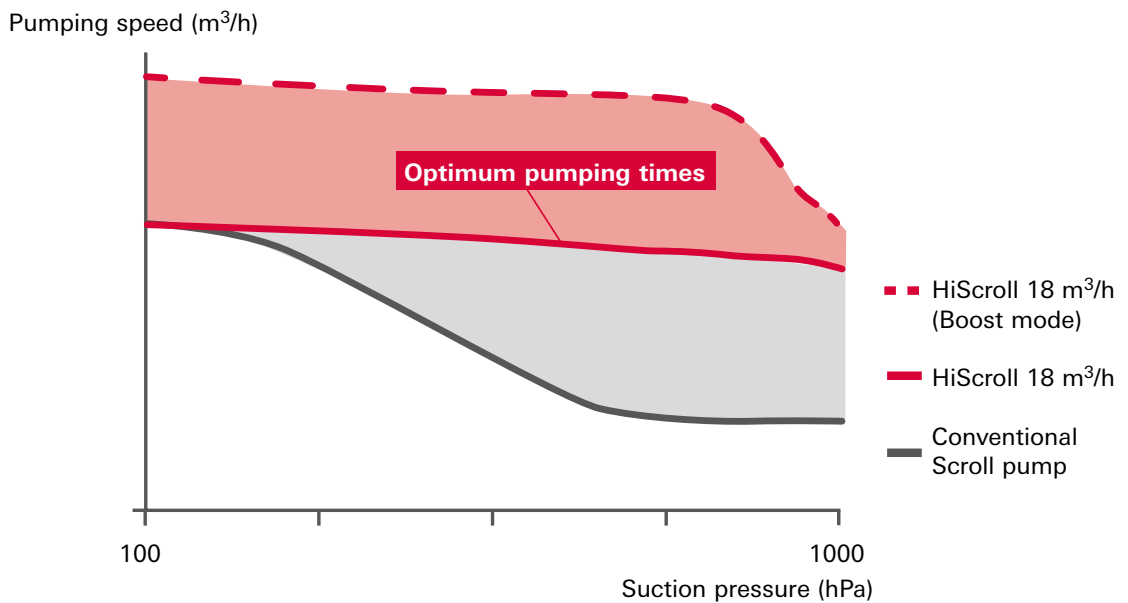

We drive sustainable solutions

Environmentally friendly

By using new IPM¹⁾ synchronous motors, our HiScroll pumps are environmentally friendly by lowering the electricity requirement while simultaneously delivering high pumping power. This results in lower operating costs for the operator: the motor achieves premium efficiency and clearly exceeds the minimum values of the IE3 efficiency level, which applies to standard asynchronous motors. That is an advantage for everyone.

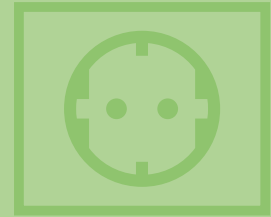

Additionally, the use of the new IPM motor technology results in significantly smaller product dimensions compared to products that are equipped with asynchronous motors.

Conserving resources

However, environmental benefits are not limited to the performance and dimensions of the pump. Our HiScroll scores points in lowering production costs due to savings on materials. For example, less copper is used and thanks to new technologies, additional sensors can be omitted. The housing of the pump as well as the cover and body of the electronics are manufactured in the casting process, thereby avoiding excessive production waste.

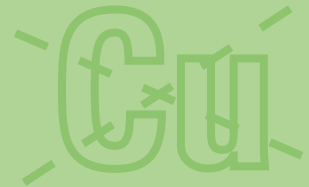

Even when it came to packaging, we thought about conserving resources: Weight-optimized and space-saving insulation materials effectively protect our HiScroll from damage in transit and at the same time ensure an optimized transport weight.



Sustainable





Last but not least, man and machine benefit equally from the sustainable use of state-of-the-art technologies: the new generation of scroll pumps emit less heat and also have a longer service life thanks to the innovative standby mode. They run extremely quietly and with little vibration, so your working environment is safe and comfortable.

¹⁾ Interior Permanent Magnet





Pumping speed and dimensions

Pumping speed

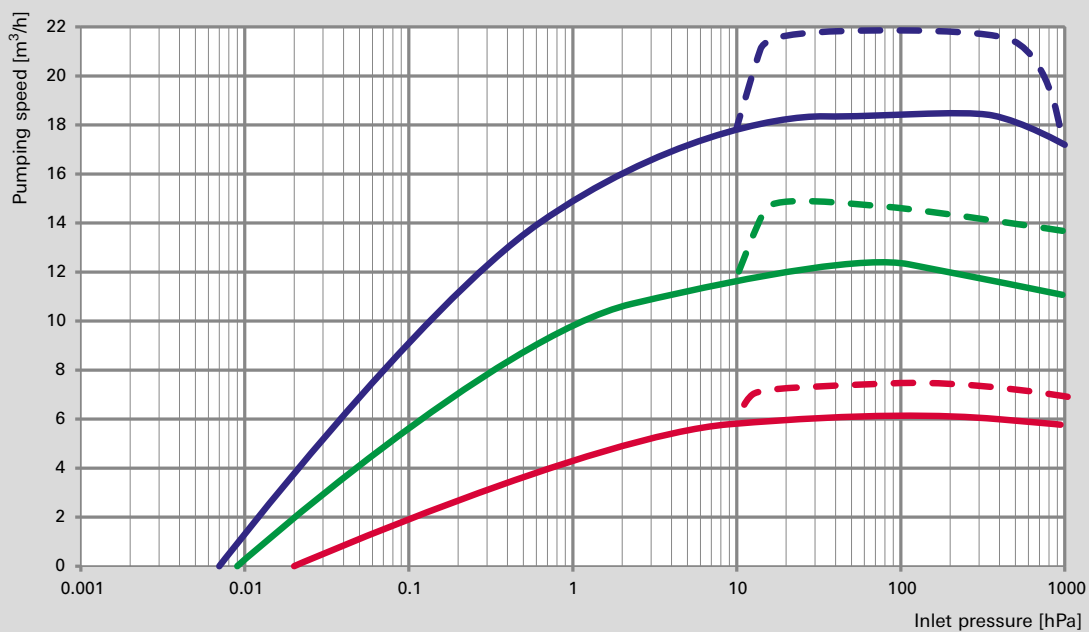
Boost mode 
 HiScroll 18 
 HiScroll 12 
 HiScroll 6 

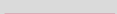

Pump down curve 100 l chamber

HiScroll 18 
 HiScroll 12 
 HiScroll 6 

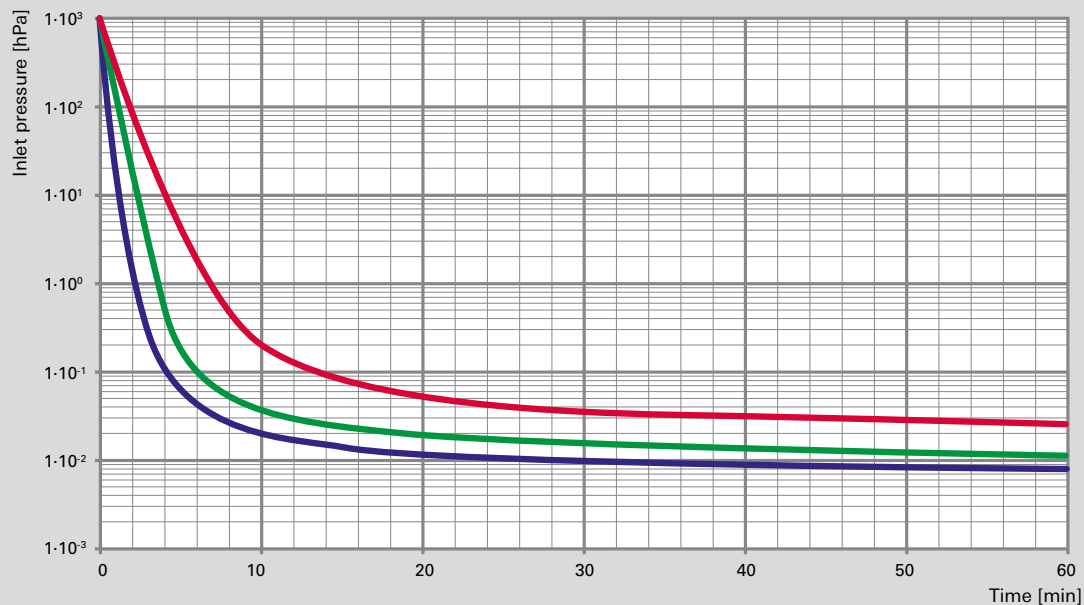

Dimensions

HiScroll 6

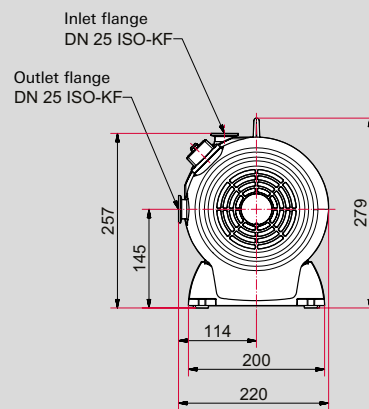
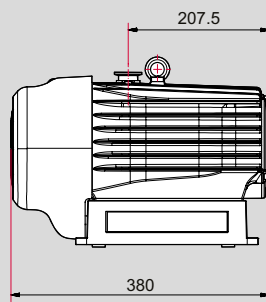
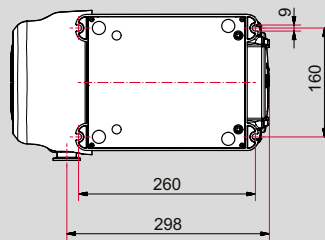

HiScroll 12 / HiScroll 18

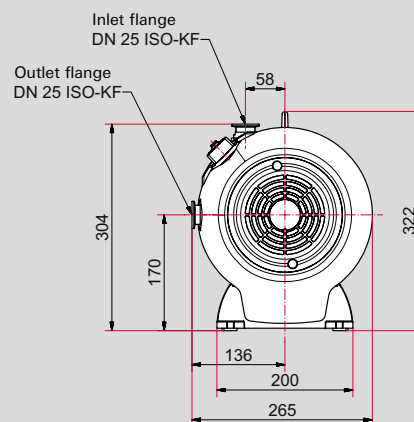
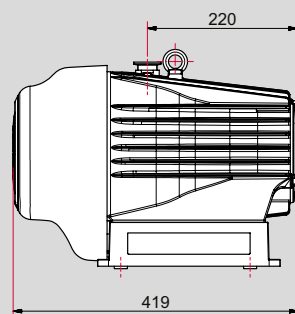
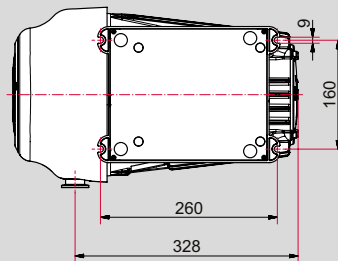

Dimensions in mm

Technical data, order numbers and accessories

Technical data

	HiScroll 6	HiScroll 12	HiScroll 18
Flange (in)	DN 25 ISO-KF	DN 25 ISO-KF	DN 25 ISO-KF
Flange (out)	DN 25 ISO-KF	DN 25 ISO-KF	DN 25 ISO-KF
Pumping speed	6.1 m ³ /h	12.1 m ³ /h	18.1 m ³ /h
Rotational speed	1,000–2,500 rpm	624–1,560 rpm	624–1,560 rpm
Typical ultimate pressure	2 · 10 ⁻² hPa	9 · 10 ⁻³ hPa	7 · 10 ⁻³ hPa
Typical ultimate pressure with gas ballast level 1	7 · 10 ⁻² hPa	5 · 10 ⁻² hPa	3 · 10 ⁻² hPa
Typical ultimate pressure with gas ballast level 2	4 · 10 ⁻¹ hPa	4 · 10 ⁻¹ hPa	2 · 10 ⁻¹ hPa
Integrated leak rate	5 · 10 ⁻⁷ Pa m ³ /s	5 · 10 ⁻⁷ Pa m ³ /s	5 · 10 ⁻⁷ Pa m ³ /s
Ambient temperature	5–40 °C	5–40 °C	5–40 °C
Exhaust pressure, max.	1,500 hPa	1,500 hPa	1,500 hPa
Intake pressure max.	1,100 hPa	1,100 hPa	1,100 hPa
Recommended continuous inlet pressure, max.	200 hPa	200 hPa	200 hPa
Gas ballast level 1	11 l/min	18 l/min	23 l/min
Gas ballast level 2	16 l/min	30 l/min	30 l/min
Gas ballast inlet pressure max.	1,500 hPa	1,500 hPa	1,500 hPa
Mains 50/60 Hz	100 – 127 / 200 – 240 V AC (±10 %), 50/60 Hz		
Max. Current	100 V–127 V: 4 A	100 V–127 V: 8 A	100 V–127 V: 10 A
	200 V–240 V: 2 A	200 V–240 V: 4 A	200 V–240 V: 6 A
Rated current consumption	100 V–127 V: 4 A	100 V–127 V: 8 A	100 V–127 V: 10 A
	200 V–240 V: 2 A	200 V–240 V: 4 A	200 V–240 V: 6 A
Protection category	IP 20	IP 20	IP 20
I/O Interfaces	RS-485	RS-485	RS-485
Cooling method, standard	Active air cooling	Active air cooling	Active air cooling
Check valve	Yes	Yes	Yes
Emission sound pressure level (EN ISO 2151)	48 dB(A)	47 dB(A)	47 dB(A)
Dimension	380x220x257 mm	419x265x304 mm	419x265x304 mm
Weight	19 kg	24 kg	23 kg

Order number matrix

Size	a
HiScroll 6	1
HiScroll 12	2
HiScroll 18	3

Equipment	b
Standard	0
Pressure sensor	1

Order number

PD Sa00b0

Accessories

	Order numbers
Accessories cables	
Mains cable 230 V AC, CEE 7/7 to C13, 3 m	P 4564 309 ZA
Mains cable 115 V AC, NEMA 5-15 to C13, 3 m	P 4564 309 ZL
Interface cable, M12 m straight/M12 m straight, 3 m	PM 061 283 -T
USB converter to RS-485 interface	PM 061 207 -T
Adapter, RS-485 M12	PE 100 150 -X
Y-Connector M12 to RS-485	P 4723 010
Remote controller	
DCU 002, Display Control Unit	PM 061 348 AT
HPU 001, Handheld Programming Unit	PM 051 510 -T
Pressure sensors	
RPT 010, Digital Piezo/Pirani Sensor with adapter plug	PE 100 183 -X
Filter	
SAS 25 S, Dust separator with polyester filter insert	PK Z60 507
Components	
Push-in fitting G 1/8" inclusive seal for hose connection (8/6 mm)	P 4131 029
Closure cap for gas ballast valve	PD 100 067

VACUUM SOLUTIONS FROM A SINGLE SOURCE

Pfeiffer Vacuum stands for innovative and custom vacuum solutions worldwide, technological perfection, competent advice and reliable service.

COMPLETE RANGE OF PRODUCTS

From a single component to complex systems:

We are the only supplier of vacuum technology that provides a complete product portfolio.

COMPETENCE IN THEORY AND PRACTICE

Benefit from our know-how and our portfolio of training opportunities!

We support you with your plant layout and provide first-class on-site service worldwide.

Are you looking for a
perfect vacuum solution?
Please contact us:

Pfeiffer Vacuum GmbH
Germany
T +49 6441 802-0

www.pfeiffer-vacuum.com



Follow us on social media
#pfeiffervacuum

All information is subject to change without prior notice. PU 0066 PEN (October 2020/Prod)

PFEIFFER  **VACUUM**