

DUO 11 ATEX

**Magnetically coupled rotary vane pumps with ATEX certification.
Meet highest requirements for explosion protection.**

Explosion protected

Pfeiffer Vacuum has developed the Duo 11 ATEX rotary vane pump especially for processes that take place in explosive environments or for evacuating explosive gases and vapors. It is certified in accordance with ATEX directive 2014/34/EU and meets the high requirements for explosion protection.

The ATEX certification is valid for the interior and exterior of the pump. The pump corresponds to equipment category 3G and temperature class T4. All gases up to explosive group IIC can be pumped.

Magnetically coupled

The pumping speed is 9 m³/h at 50 Hz and 10.5 m³/h at 60 Hz. The Duo 11 ATEX is equipped with a frictionless magnetic coupling. Thus, the shaft seals that are usually installed in rotary vane pumps can be omitted. The magnetic coupling provides additional safety that is particularly important when the pump is used in potentially explosive atmospheres: No gases can leak through defective seals from the interior of the pump to the exterior.

Safe

For the operation of the pump, the terms of the operating instructions apply. We are pleased to provide you with the right solution for your specific application!

Customer benefits

- Installation without additional flame arresters possible
- Pump is hermetically sealed – no zone entrainment of explosive gases
- Explosion proof internally and externally – flexible operation
- Ex-proof three-phase motor with low noise and vibration
- Most compact pump in class for easy integration

Applications

- Mass spectrometry
- Chemical laboratories
- Gas handling
- Biotechnology

Dimensions

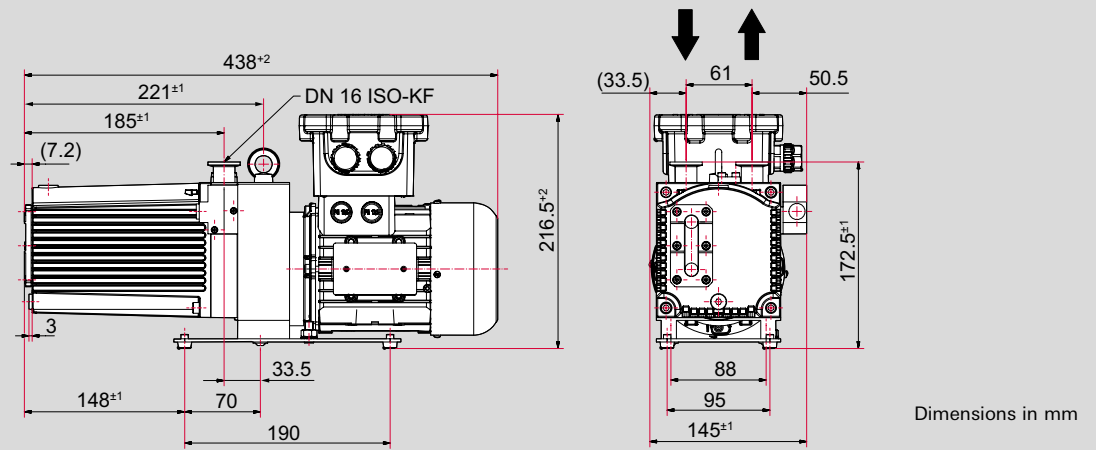

Pumping speed

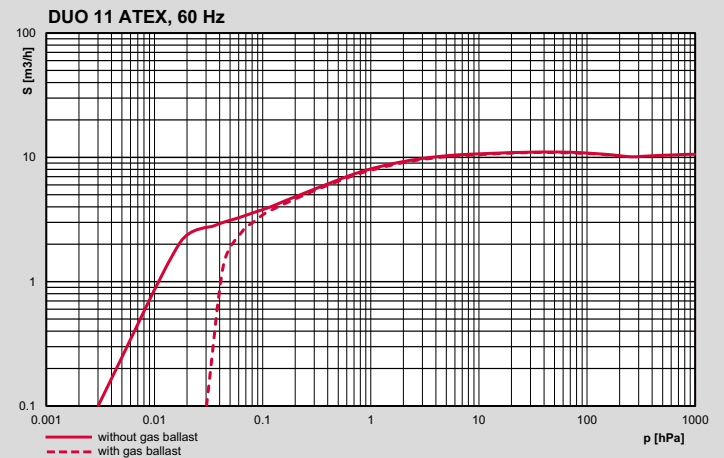
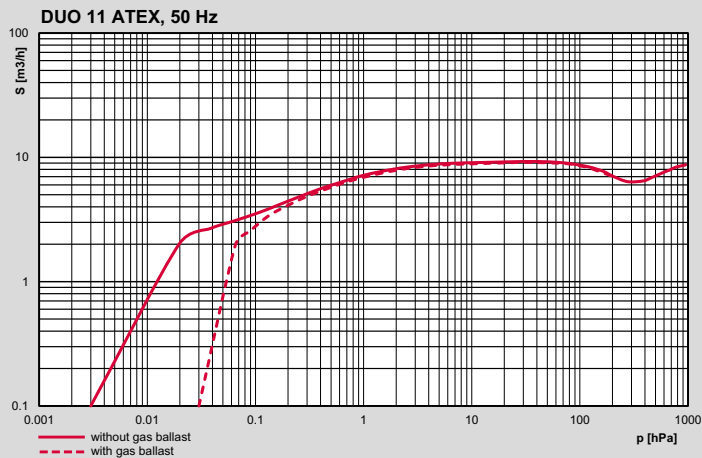

Technical data

	Duo 11 ATEX
Dimensions (L x W x H)	440 x 146 x 219 mm
Flange (in)	DN 16 ISO-KF
Flange (out)	DN 16 ISO-KF
Pumping speed at 50 Hz	9 m ³ /h
Pumping speed at 60 Hz	10.5 m ³ /h
Ultimate pressure with gas ballast	3 · 10 ⁻² hPa
Ultimate pressure without gas ballast	3 · 10 ⁻³ hPa
Exhaust pressure, min	250 hPa
Exhaust pressure, max	1,500 hPa
Rotation speed at 50 Hz	3,000 min ⁻¹
Rotation speed at 60 Hz	3,600 min ⁻¹
Leak rate safety valve	≤ 1 · 10 ⁻⁵ Pa m ³ /s
Emission sound pressure level without gas ballast at 50 Hz	53 dB (A)
Ambient temperature	12–40 °C
Protection category	IP66
Rated power 50 Hz	0.25 kW
Rated power 60 Hz	0.3 kW
Transport-und Lagertemperatur	-10 – +40 °C
Operating fluid	P3
Operating fluid filling	0.5 l
Weight	15.3 kg
Cooling method, standard	Air
Typical ultimate pressure according to PNEUROP	

Order number

	Order number
Duo 11 ATEX	PK D59 905

VACUUM SOLUTIONS FROM A SINGLE SOURCE

Pfeiffer Vacuum stands for innovative and custom vacuum solutions worldwide, technological perfection, competent advice and reliable service.

COMPLETE RANGE OF PRODUCTS

From a single component to complex systems:

We are the only supplier of vacuum technology that provides a complete product portfolio.

COMPETENCE IN THEORY AND PRACTICE

Benefit from our know-how and our portfolio of training opportunities!

We support you with your plant layout and provide first-class on-site service worldwide.

Are you looking for a
perfect vacuum solution?
Please contact us:

Pfeiffer Vacuum GmbH
Headquarters · Germany
T +49 6441 802-0
info@pfeiffer-vacuum.de

Sie suchen eine perfekte
Vakuumlösung?
Sprechen Sie uns an:

www.pfeiffer-vacuum.com