



# Pascal 2005, SD version, 1-phase motor, 180-254 V, 50 Hz/60 Hz, CE/UL/CSA



Similar Image

**Pascal 2005, SD version, 1-phase motor, 180-254 V, 50 Hz/60 Hz, CE/UL/CSA**

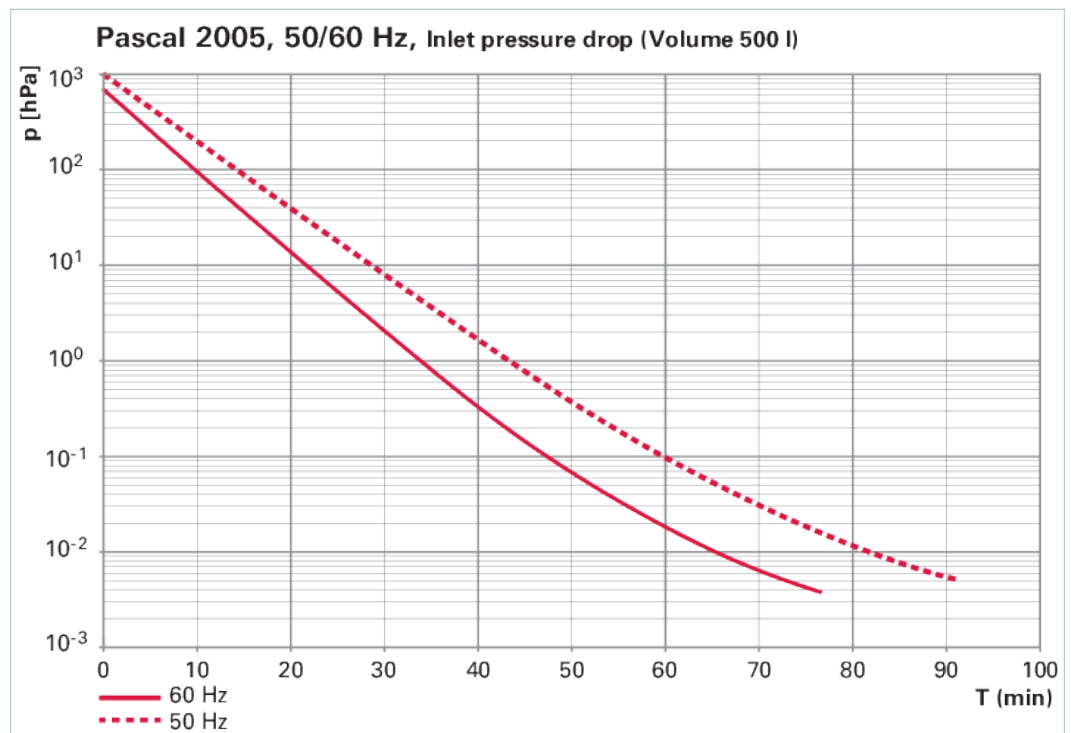
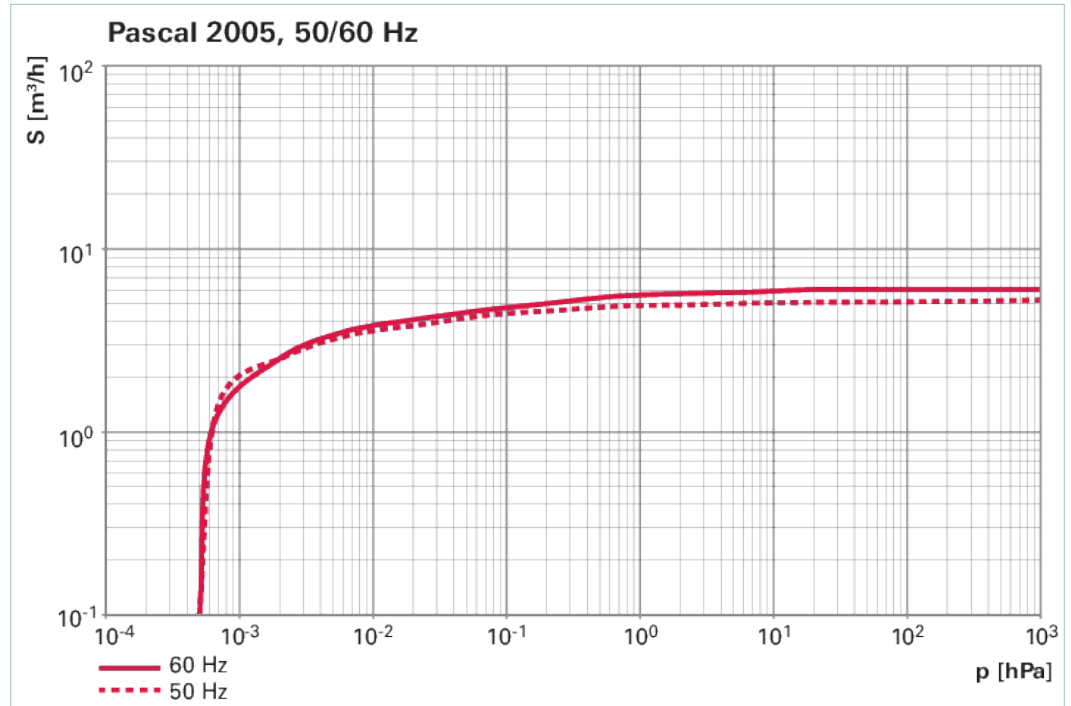

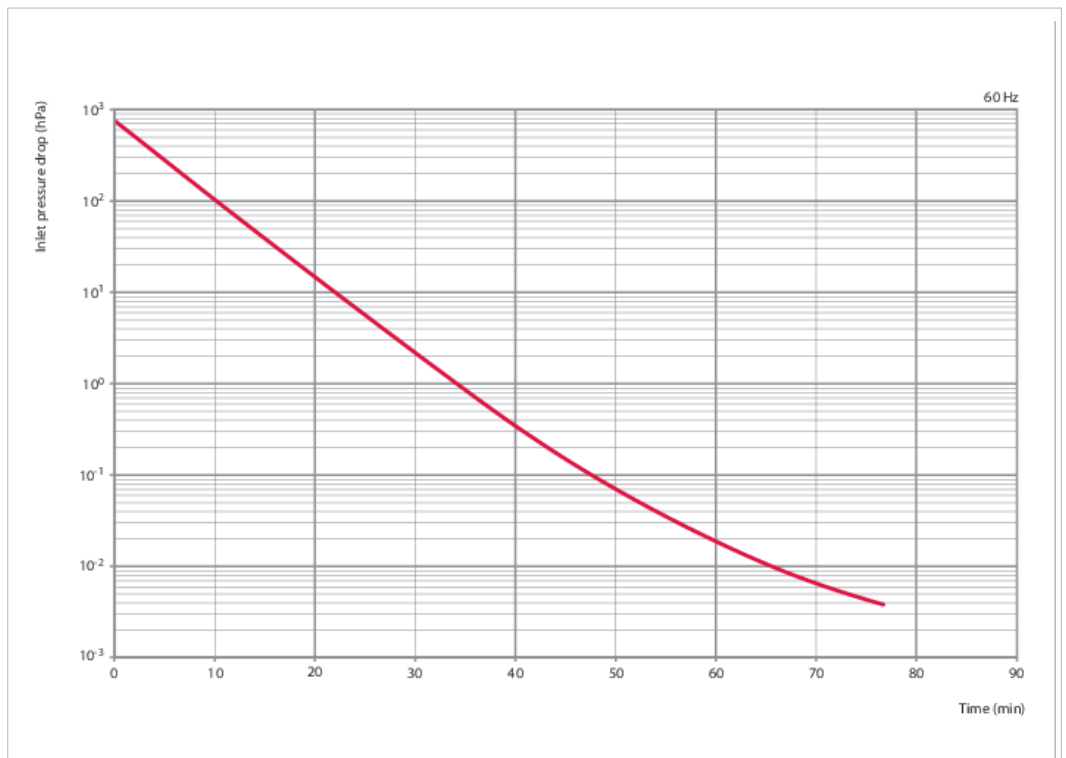

### Dimensions

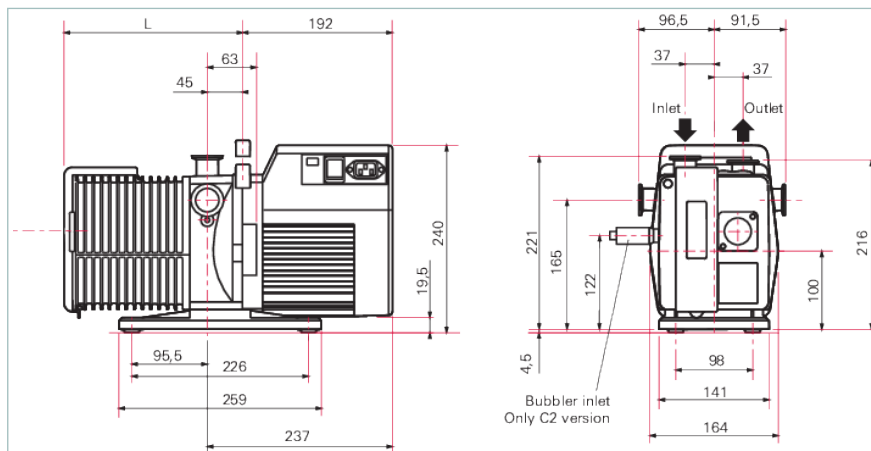

L 228 mm

Technical Data	Pascal 2005, SD version, 1-phase motor, 180-254 V, 50 Hz/60 Hz, CE/UL/CSA
Flange (in)	DN 25 ISO-KF
Flange (out)	DN 25 ISO-KF
Mains requirement: voltage 50 Hz	180 – 254 V
Mains requirement: voltage 60 Hz	180 – 254 V
Motor version	1-phase Motor
Operating fluid	Mineral oil
Pumping speed at 50 Hz	5 m <sup>3</sup> /h
Pumping speed at 60 Hz	6 m <sup>3</sup> /h
Rated power 50 Hz	0.45 kW
Rated power 60 Hz	0.55 kW
Ultimate pressure	5 · 10 <sup>-4</sup> hPa   3.75 · 10 <sup>-4</sup> Torr   5 · 10 <sup>-4</sup> mbar
Ultimate pressure with gas ballast	1 · 10 <sup>-2</sup> hPa   7.5 · 10 <sup>-3</sup> Torr   1 · 10 <sup>-2</sup> mbar
Version	Standard
Weight	25 kg   55.12 lb

Order number	
Pascal 2005 SD	205SDMHEM

Accessories	
<b>Magnetic gas ballast valve</b>	
Automatic gas ballast AGB 4, 230 V, 50/60 Hz	104086
Automatic gas ballast AGB 4, 115 V	104087
Automatic gas ballast AGB 4, 24 VDC	104089
Automatic gas ballast AGB 4, 200 V, 50/60 Hz	104366
<b>Zeolite trap</b>	
Sorption trap ST 25 S	104107
<b>OME S</b>	
Oil mist eliminator OME 25 S	104200
<b>Operating fluid return line from operating fluid mist filter</b>	
Oil drain kit ODK 1 from oil mist eliminator	104360
Oil return unit ODK 2 from OME 25, magnetic valve 230 V 50/60 Hz, Pascal 2005–2021	104361
Oil return unit ODK 2 from OME 25, Pascal 2005–2021, magnetic valve 115 V, 60 Hz	104362
Oil return unit ODK 2 from OME 25, Pascal 2005–2021, magnetic valve 200 V, 50/60 Hz	104364
Oil return unit ODK 2 from OME, Pascal 2005–2021, magnetic valve 24 V DC	104365
<b>Operating fluid level monitoring</b>	
Oil level switch OLS 4	104376
<b>KLF</b>	
KLF 025, cold trap	PK Z80 006
<b>Dust separator</b>	
SAS 25, dust separator, DN 25 ISO-KF, polyester filter	PK Z60 508
<b>URB</b>	
URB 025, catalytic trap, 115 V	PT U10 761
URB 025, catalytic trap, 230 V	PT U10 760
<b>OME M</b>	
OME 25 M, oil mist filter for pumping speeds of up to 12 m <sup>3</sup> /h	PK Z40 157
<b>Consumables</b>	
A120, hydrocarbon oil, 2 L	068099
A111, hydrocarbon oil, 2 L	064655
A102, hydrocarbon oil, 2 L	010996
A119, hydrocarbon oil, 1 L	103855
A200, Distilled hydrocarbon oil, 3,8 L	068695
A300, white mineral oil, 3,8 L	068891
A121, hydrocarbon oil, 1 L	102724
D1, synthetic diester based oil, 1 l	PK 005 875 -T

## **VACUUM SOLUTIONS FROM A SINGLE SOURCE**

Pfeiffer Vacuum stands for innovative and custom vacuum solutions worldwide, technological perfection, competent advice and reliable service.

## **COMPLETE RANGE OF PRODUCTS**

From a single component to complex systems:

We are the only supplier of vacuum technology that provides a complete product portfolio.

## **COMPETENCE IN THEORY AND PRACTICE**

Benefit from our know-how and our portfolio of training opportunities!

We support you with your plant layout and provide first-class on-site service worldwide.

Are you looking for a  
perfect vacuum solution?  
Please contact us:

**Pfeiffer Vacuum GmbH**  
Headquarters · Germany  
T +49 6441 802-0  
info@pfeiffer-vacuum.de

[www.pfeiffer-vacuum.com](http://www.pfeiffer-vacuum.com)

All data subject to change without prior notice.

**PFEIFFER**  **VACUUM**