



Pascal 2010, SD version, 1-phase motor, 180-254 V, 50 Hz/60 Hz, CE/UL/CSA



Similar Image

Pascal 2010, SD version, 1-phase motor, 180-254 V, 50 Hz/60 Hz, CE/UL/CSA

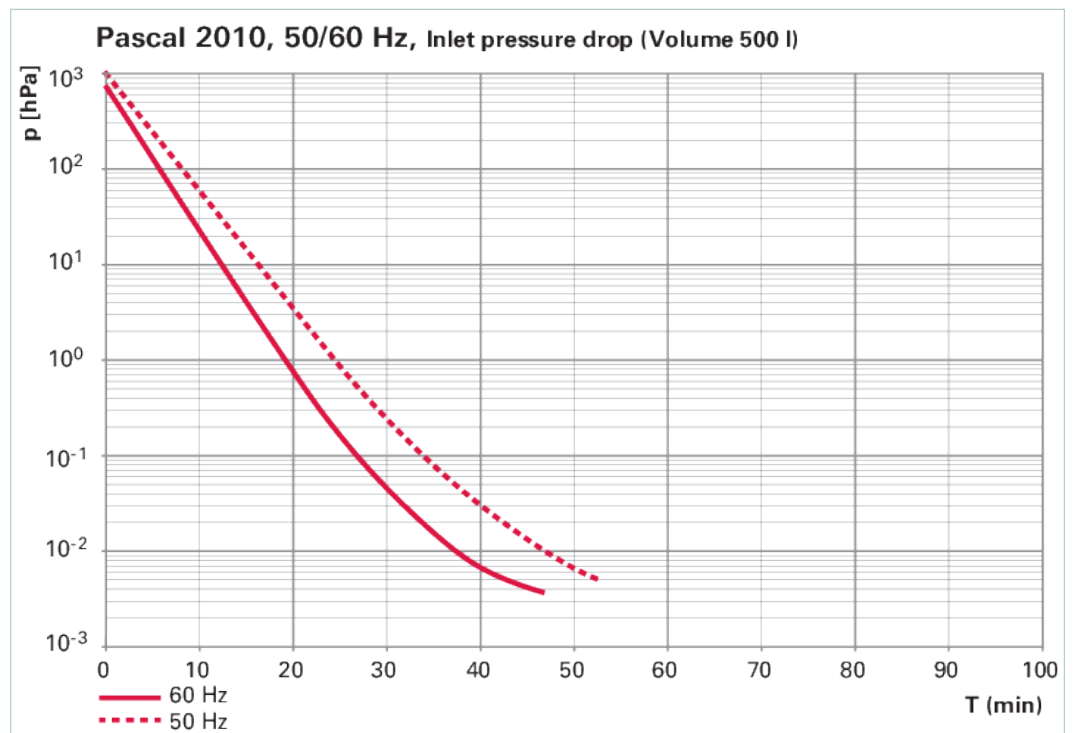
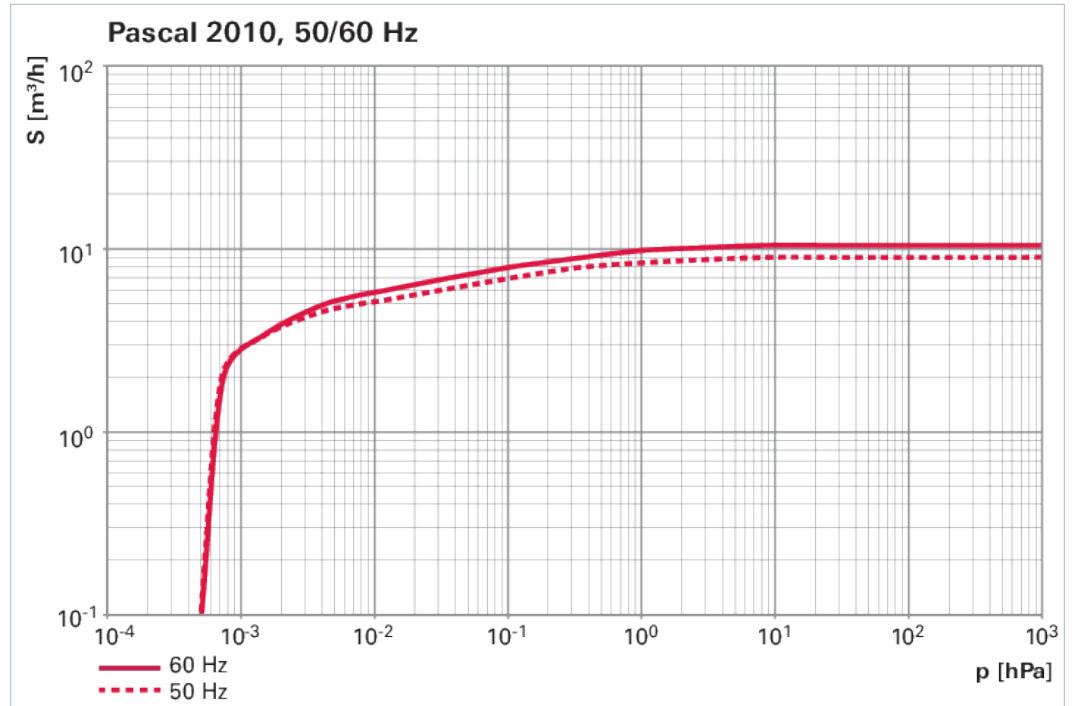

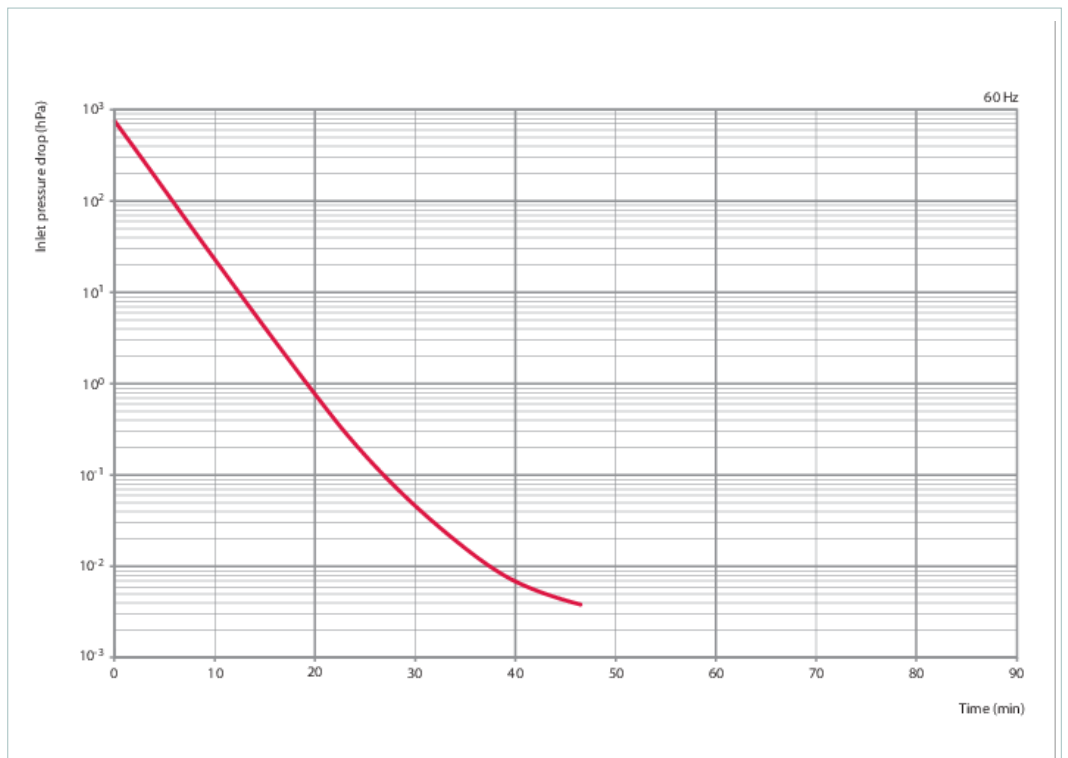

Dimensions

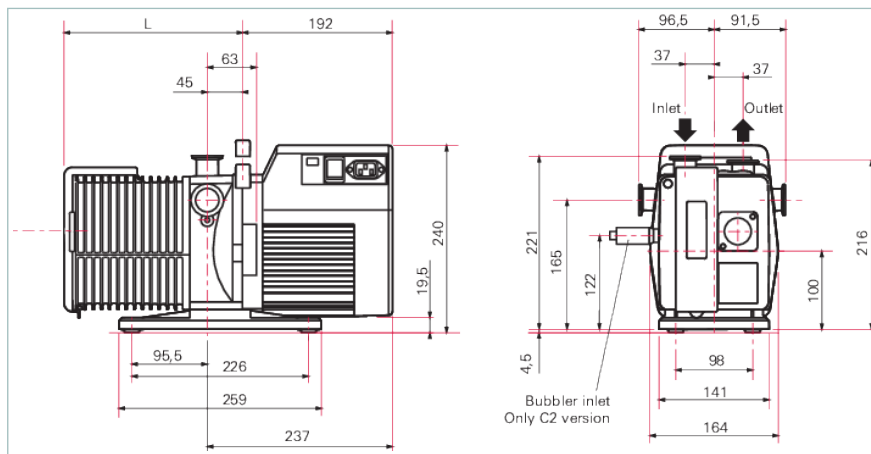

L 245 mm

Technical Data	Pascal 2010, SD version, 1-phase motor, 180-254 V, 50 Hz/60 Hz, CE/UL/CSA
Flange (in)	DN 25 ISO-KF
Flange (out)	DN 25 ISO-KF
Mains cable	Europe
Mains requirement: voltage 50 Hz	180 – 254 V
Mains requirement: voltage 60 Hz	180 – 254 V
Motor version	1-phase Motor
Operating fluid	Mineral oil
Protection category	IP43
Pumping speed at 50 Hz	9 m ³ /h
Pumping speed at 60 Hz	10.5 m ³ /h
Pumping speed range	10 m ³ /h
Rated power 50 Hz	0.45 kW
Rated power 60 Hz	0.55 kW
Ultimate pressure	5 · 10 ⁻⁴ hPa 3.75 · 10 ⁻⁴ Torr 5 · 10 ⁻⁴ mbar

Technical Data	Pascal 2010, SD version, 1-phase motor, 180-254 V, 50 Hz/60 Hz, CE/UL/CSA
Ultimate pressure with gas ballast	1 · 10 ⁻² hPa 7.5 · 10 ⁻³ Torr 1 · 10 ⁻² mbar
Version	Standard
Weight	26 kg 57.32 lb

Order number	
Pascal 2010 SD	210SDMHEM

Accessories	
Magnetic gas ballast valve	
Automatic gas ballast AGB 4, 230 V, 50/60 Hz	104086
Automatic gas ballast AGB 4, 115 V	104087
Automatic gas ballast AGB 4, 24 VDC	104089
Automatic gas ballast AGB 4, 200 V, 50/60 Hz	104366
Other	
Sorption trap ST 25 S	104107
OME S	
Oil mist eliminator OME 25 S	104200
Operating fluid return line from operating fluid mist filter	
Oil drain kit ODK 1 from oil mist eliminator	104360
Oil return unit ODK 2 from OME 25, magnetic valve 230 V 50/60 Hz, Pascal 2005–2021	104361
Oil return unit ODK 2 from OME 25, Pascal 2005–2021, magnetic valve 115 V, 60 Hz	104362
Oil return unit ODK 2 from OME 25, Pascal 2005–2021, magnetic valve 200 V, 50/60 Hz	104364
Oil return unit ODK 2 from OME, Pascal 2005–2021, magnetic valve 24 V DC	104365
Operating fluid level monitoring	
Oil level switch OLS 4	104376
Condensate separators	
KAS 25 L, condensate separator for pumping speeds up to 35 m ³ /h	PK Z10 033
OME M	
OME 25 M, oil mist filter for pumping speeds of up to 12 m ³ /h	PK Z40 157
Dust separator	
SAS 25, dust separator, DN 25 ISO-KF, polyester filter	PK Z60 508
KLF	
KLF 025, cold trap	PK Z80 006
URB	
URB 025, catalytic trap, 230 V	PT U10 760
URB 025, catalytic trap, 115 V	PT U10 761
Consumables	
A120, hydrocarbon oil, 2 L	068099
A111, hydrocarbon oil, 2 L	064655
A102, hydrocarbon oil, 2 L	010996
A119, hydrocarbon oil, 1 L	103855
A300, white mineral oil, 3,8 L	068891
A121, hydrocarbon oil, 1 L	102724
D1, synthetic diester based oil, 1 l	PK 005 875 -T

VACUUM SOLUTIONS FROM A SINGLE SOURCE

Pfeiffer Vacuum stands for innovative and custom vacuum solutions worldwide, technological perfection, competent advice and reliable service.

COMPLETE RANGE OF PRODUCTS

From a single component to complex systems:

We are the only supplier of vacuum technology that provides a complete product portfolio.

COMPETENCE IN THEORY AND PRACTICE

Benefit from our know-how and our portfolio of training opportunities!

We support you with your plant layout and provide first-class on-site service worldwide.

Are you looking for a
perfect vacuum solution?
Please contact us:

Pfeiffer Vacuum GmbH
Headquarters · Germany
T +49 6441 802-0
info@pfeiffer-vacuum.de

www.pfeiffer-vacuum.com

All data subject to change without prior notice.

PFEIFFER  **VACUUM**