



**Pascal 2011, SD version, 3-phase
motor, 342-460 V, 50 Hz; 342-520
V, 60 Hz, CE/UL/CSA**



Similar Image

**Pascal 2021, SD version, 3-phase motor, 342-460 V, 50 Hz;
342-520 V, 60 Hz, CE/UL/CSA**

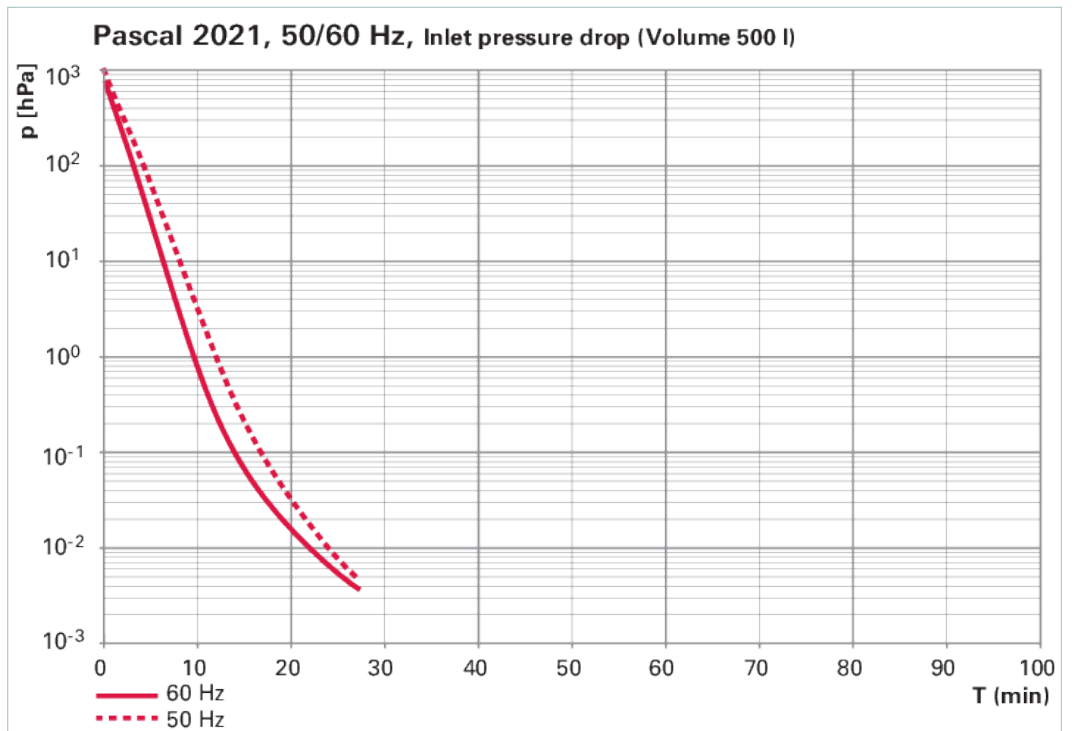
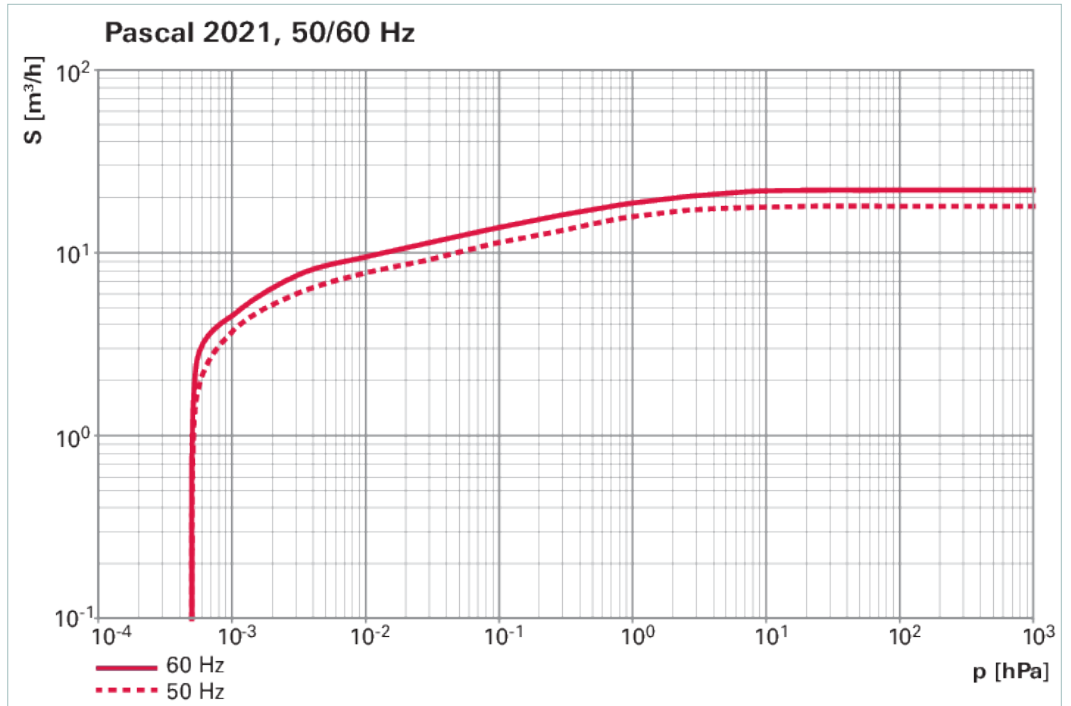

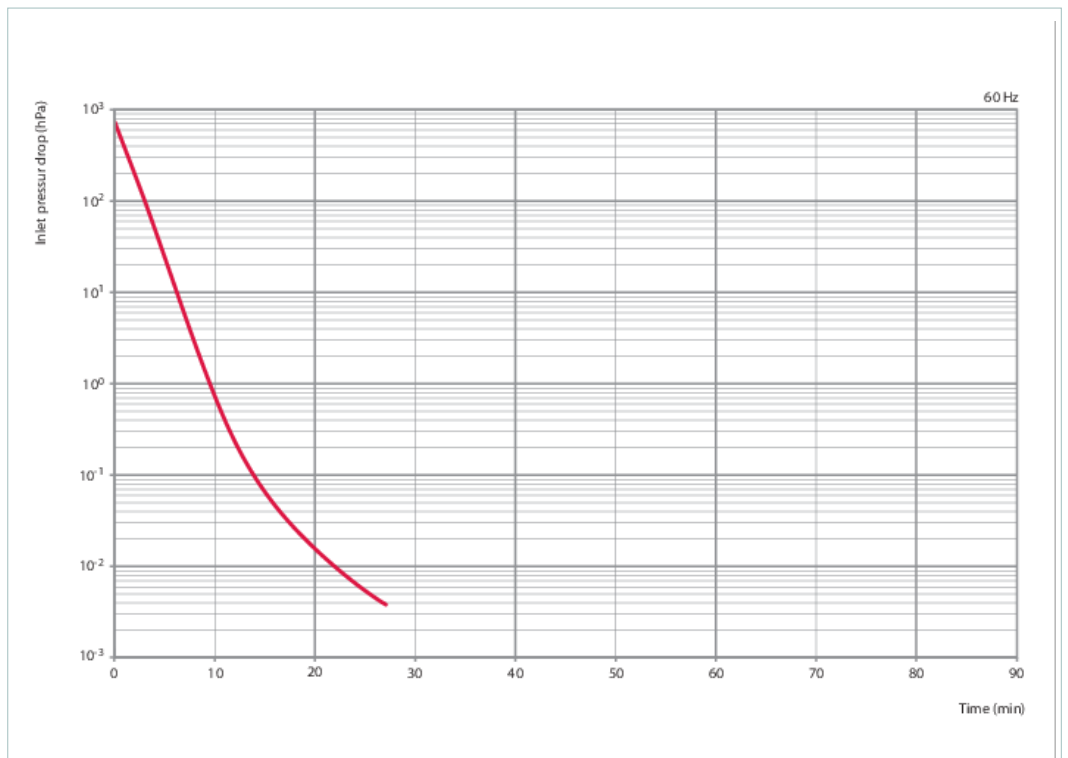

Dimensions

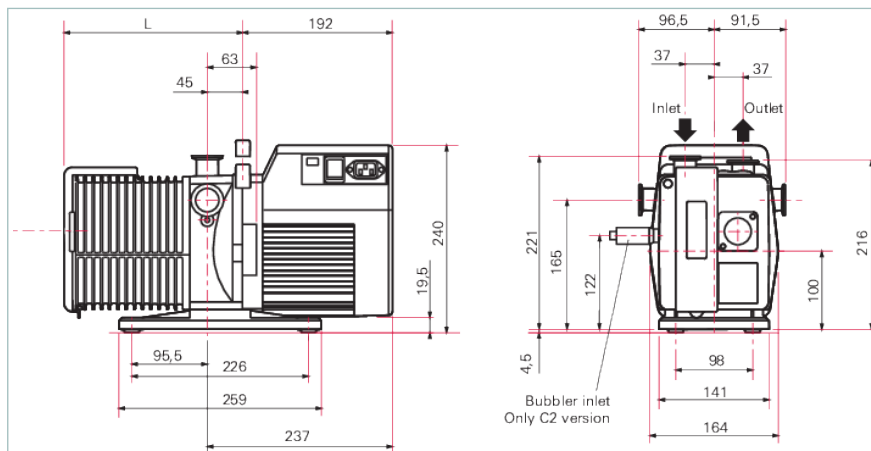

L 291 mm

Technical Data

Pascal 2021, SD version, 3-phase motor, 342-460 V, 50 Hz; 342-520 V, 60 Hz, CE/UL/CSA

| | |
|------------------------------------|---|
| Flange (in) | DN 25 ISO-KF |
| Flange (out) | DN 25 ISO-KF |
| Mains requirement: voltage 50 Hz | 342 – 460 V |
| Mains requirement: voltage 60 Hz | 342 – 520 V |
| Operating fluid | Mineral oil |
| Pumping speed at 50 Hz | 18 m ³ /h |
| Pumping speed at 60 Hz | 22 m ³ /h |
| Rated power 50 Hz | 0.55 kW |
| Rated power 60 Hz | 0.66 kW |
| Ultimate pressure | 5 · 10 ⁻⁴ hPa 3.75 · 10 ⁻⁴ Torr 5 · 10 ⁻⁴ mbar |
| Ultimate pressure with gas ballast | 1 · 10 ⁻² hPa 7.5 · 10 ⁻³ Torr 1 · 10 ⁻² mbar |
| Version | Standard |
| Weight | 28 kg 61.73 lb |

| Order number | |
|----------------|-----------|
| Pascal 2021 SD | 221SDTHEM |

| Accessories | |
|---|---------------|
| Magnetic gas ballast valve | |
| Automatic gas ballast AGB 4, 230 V, 50/60 Hz | 104086 |
| Automatic gas ballast AGB 4, 115 V | 104087 |
| Automatic gas ballast AGB 4, 24 VDC | 104089 |
| Automatic gas ballast AGB 4, 200 V, 50/60 Hz | 104366 |
| Zeolite trap | |
| Sorption trap ST 25 S | 104107 |
| OME S | |
| Oil mist eliminator OME 25 S | 104200 |
| Operating fluid return line from operating fluid mist filter | |
| Oil drain kit ODK 1 from oil mist eliminator | 104360 |
| Oil return unit ODK 2 from OME 25, magnetic valve 230 V 50/60 Hz, Pascal 2005–2021 | 104361 |
| Oil return unit ODK 2 from OME 25, Pascal 2005–2021, magnetic valve 115 V, 60 Hz | 104362 |
| Oil return unit ODK 2 from OME 25, Pascal 2005–2021, magnetic valve 200 V, 50/60 Hz | 104364 |
| Oil return unit ODK 2 from OME, Pascal 2005–2021, magnetic valve 24 V DC | 104365 |
| Operating fluid level monitoring | |
| Oil level switch OLS 4 | 104376 |
| Dust separator | |
| SAS 25, dust separator, DN 25 ISO-KF, polyester filter | PK Z60 508 |
| KLF | |
| KLF 025, cold trap | PK Z80 006 |
| URB | |
| URB 025, catalytic trap, 230 V | PT U10 760 |
| URB 025, catalytic trap, 115 V | PT U10 761 |
| OME M | |
| OME 25 ML, oil mist filter for pumping speeds of up to 30 m ³ /h | PK Z40 158 |
| Consumables | |
| A120, hydrocarbon oil, 2 L | 068099 |
| A111, hydrocarbon oil, 2 L | 064655 |
| A102, hydrocarbon oil, 2 L | 010996 |
| A119, hydrocarbon oil, 1 L | 103855 |
| A200, Distilled hydrocarbon oil, 3,8 L | 068695 |
| A300, white mineral oil, 3,8 L | 068891 |
| A121, hydrocarbon oil, 1 L | 102724 |
| D1, synthetic diester based oil, 1 l | PK 005 875 -T |

VACUUM SOLUTIONS FROM A SINGLE SOURCE

Pfeiffer Vacuum stands for innovative and custom vacuum solutions worldwide, technological perfection, competent advice and reliable service.

COMPLETE RANGE OF PRODUCTS

From a single component to complex systems:

We are the only supplier of vacuum technology that provides a complete product portfolio.

COMPETENCE IN THEORY AND PRACTICE

Benefit from our know-how and our portfolio of training opportunities!

We support you with your plant layout and provide first-class on-site service worldwide.

Are you looking for a
perfect vacuum solution?
Please contact us:

Pfeiffer Vacuum GmbH
Headquarters · Germany
T +49 6441 802-0
info@pfeiffer-vacuum.de

www.pfeiffer-vacuum.com

All data subject to change without prior notice.

PFEIFFER  **VACUUM**